



DCN: 3.02.02

FIREFIGHTING PROCEDURES

LADDERS 3

October 6, 2000

TENEMENTS

FIREFIGHTING PROCEDURES

LADDER COMPANY OPERATIONS III

VOLUME III - BOOK 3

TENEMENTS

COPYRIGHT 2000 NEW YORK CITY FIRE DEPARTMENT

GLOSSARY

| | |
|--|---|
| Air Shaft | A space between buildings or between rooms within a building, providing for the purpose of admitting air and light to rooms. |
| Auto Exposure | The extension of fire in or on the exterior of a building from a fire originating in the same building. |
| Backdraft | A rapid, almost instantaneous, combustion of flammable gases which flashes or explodes within and back through openings around a fire area upon the introduction of fresh air (oxygen). |
| Beam | A horizontal supporting member in building construction. |
| Bearing Wall | A wall of a building that carries any load other than its own weight. |
| Bulkhead | A structure on the roof of a building which is built over or encloses a stairway, elevator, dumbwaiter or other building facility. |
| Cantilever Position | A projecting beam or other structure supported only at one end. E.g., the extended tip of an Aerial ladder unsupported from a structure. (not touching) |
| Carbon Monoxide | A colorless, odorless, very poisonous gas formed when carbon burns with an insufficient supply of air. The chief danger with most fire gases is that, although not the most toxic, carbon monoxide is almost always the most abundant.. |
| Child Guard Gate | A fixed device that partially covers the lower part of a window to prevent a child from falling out. |
| Class "A" Multiple Dwelling | A building housing three or more families in which residency is permanent in nature. |
| Class "B" Multiple Dwelling | A multiple dwelling which is occupied transiently. |
| Coaming | A raised frame around a floor or roof opening or scuttle to keep water from running in. |
| Cockloft | A space between the roof and the top floor ceiling. |
| Coffin Cut | A cut made as that resembling a rectangle. Generally this cut is made perpendicular to the supporting beams below, to vent or expose as many bays as possible. |
| Column | A vertical structural member in building construction. |
| Compactor | A device for crushing garbage and trash into a small space prior to removal from the premises. |
| Drop Ladder | A vertical ladder normally held in the "up" position at the second floor balcony of the fire escape by a hook. When this ladder is to be used, the hook is released and the drop ladder is lowered or dropped to the ground. Care must be exercised to make certain that no one is struck by this ladder when it is lowered or dropped to the ground. |

| | |
|---------------------------------------|--|
| Dumbwaiter | A device for collecting garbage from apartments by means of a wooden car which is raised and lowered in a vertical shaft by means of a rope and a pulley. In most buildings these dumbwaiters are no longer used. |
| Energy Efficient Windows (EEW) | A window designed to maintain an air tight insulation, and will contain more than one pane of glass with an air tight space in-between. |
| Exposures #1, #2, #3 & #4 | A system of designating the areas or buildings which are adjacent to the fire building. When facing the main entrance to the fire building, exposure #1 is in front of the building, #2 is on the left, #3 is to the rear of the fire building and #4 is on the right. |
| Fire Escape | An emergency means of egress from a building consisting of metal balconies on the outside of a building connected by ladders to each other and to the ground. Some fire escapes have a ladder from the top floor balcony to the roof. |
| Fire Stopping | The closing of all concealed draft openings to form a barrier against the spread of fire with incombustible materials. |
| Flashover | Simultaneous ignition over the entire surface of a room and its contents. This sudden full involvement is the phenomenon called "FLASHOVER", the critical point of fire progress. |
| Goose Neck Ladder | A vertical ladder, the siderails of which are curved at the top. This type of ladder is sometimes used between the top floor balcony of a fire escape and the roof. |
| H.T. | Handi-Talkie |
| Incident Commander | Highest ranking officer in charge of an Emergency or Fire operation |
| Knock Down | To have visible flame under control without complete extinguishment. |
| Lintel | A horizontal building member, supporting the weight above an opening, such as a window or a door. |
| Membrane Roof | Roofing material in roll form, consisting of asphalt materials, (bituminous) polymers of plastics and synthetics for strength. Thickness can vary. Roofs covered with this type of materials are susceptible to ignition and rapid flame spread when exposed to flame. |
| Party Wall Balcony | A structure build as an emergency means of egress from a building which will afford lateral access to an adjoining building or apartment separated by a fire wall. They do not have ladders to ascend or descend from floor to floor or the roof. |
| Rabbit Tool | A hydraulic forcible entry tool. |

| | |
|------------------------------|---|
| Raised Roof | A roof which is raised above the roof beams and supported by 2x4's. The extent to which it is raised varies, so as to provide proper drainage on the roof. The result is a large open cockloft where fire can spread easily. Also known as inverted roof. |
| Renovated Building | Any alteration to the original structural components, major or minor, that may effect fire fighting operations. |
| Return | The interior surface of a scuttle or skylight between the roof and the top floor ceiling. |
| Riding List | A list of members on duty. One copy is kept on the apparatus and one copy is carried by the officer on duty. This list (Form BF-4) also shows riding positions, tools assigned, masks assigned and group numbers for each man on the list. |
| Scuttle | An opening in the roof fitted with a lid. |
| Single Room Occupancy | A multiple dwelling which the apartments, which were formerly rented to families, are now rented as single rooms to unrelated people. These occupants use the kitchen and bathroom facilities in common. |
| Size-Up | Is an ongoing evaluation of the problems confronted within a fire situation. |
| Unprotected Steel | Steel structural components of a building which do not have any fire resistive covering such as concrete, brick, asbestos, etc.. |
| Ventilate | All those actions which are taken at a fire to allow heat and smoke to escape. Ventilation is necessary to prevent fire from extending and to permit search and advancement of hoselines. |
| VES | Ventilate, entry and search. |
| Walk Through Bulkhead | A structure at the uppermost portion of interior stairs that may isolate the front section of the roof from the rear. One must walk through the bulkhead to reach the other section of the roof. |
| Window Gate | A folding gate placed at a window to prevent intruders from entering. The type that is approved by the Board of Standards and Appeals does not have locks. |

Figure 1

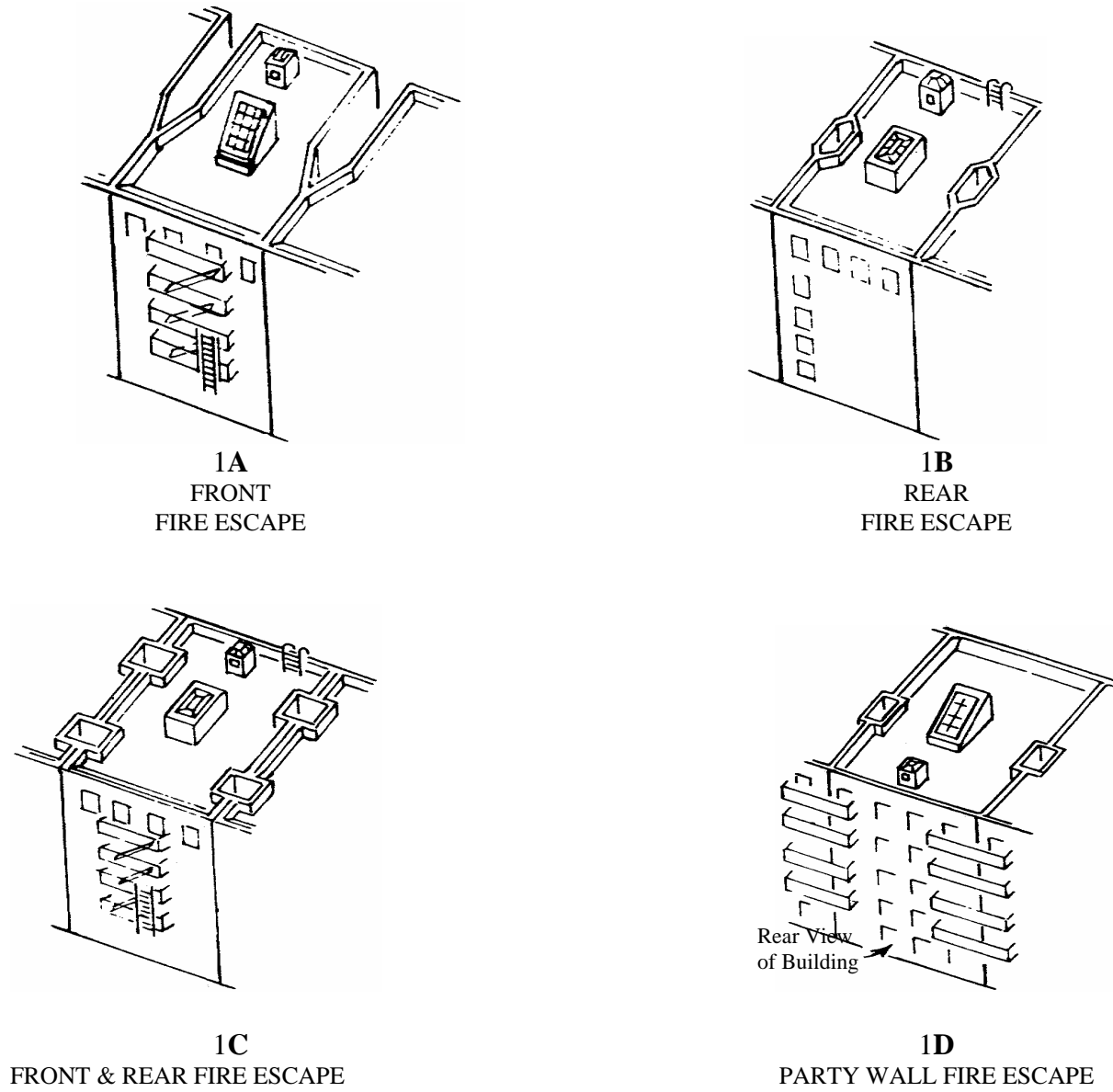
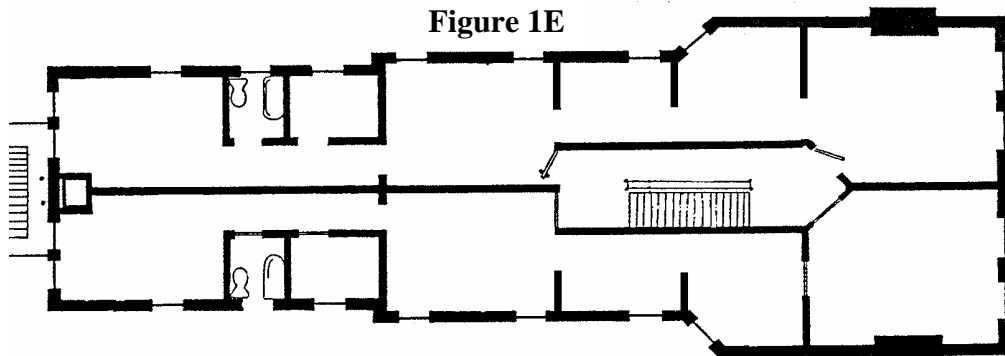

Figure 1E



Typical railroad flat in O.L.T. 1 or 2 of these apartments on each floor.

1. GENERAL

1.1 INTRODUCTION

This bulletin describes initial operations, assignments and tools used by Ladder Companies operating at fires in occupied non-fireproof tenements. All situations encountered cannot be covered in this manual. Therefore the coordinated team operations described should be followed as closely as the situation permits.

All members comply with the provisions of AUC 329. When giving assignments, the Officer on duty shall ensure members are reminded of their designations as safety team members. These members must be aware that this designation is based on their unit's order of arrival at the box and will change as additional units arrive. While operating members shall pay particular attention to the following provisions of Sections 1.2 and 1.3 which state:

"When a fire progresses past the incipient stage, the fire area must be considered an IDLH atmosphere. Every member entering the IDLH must be equipped with personal protective equipment and a self-contained breathing apparatus. No member shall enter an IDLH atmosphere unless the member teams-up with at least one other member and remains within voice or visual contact with that member."

"If a known life hazard is found and immediate action could prevent the loss of life, appropriate action (rescue activity) may be taken by the individual member. This applies only for a known life hazard, not for standard search and rescue activity. If such action is taken, the Incident Commander must be immediately notified and appropriate adjustments made."

Ladder Company assignments are given to each member at Roll Calls. During Roll Call the Officer on Duty (O.O.D.) shall inform members of hazardous conditions, safety issues, street closings, Department Orders and other pertinent information affecting the unit. (A copy of these messages shall be posted after Roll Call for members to read) Each member shall personally check his/her firefighting gear, and equipment including mask, PASS alarm, flashlight, personal rope and assigned tools. The O.O.D. shall have posted a copy of the riding positions on the blackboard. Members shall inform the officer of the results of their apparatus, tool and equipment inspections.

1.2 DESCRIPTION OLD LAW TENEMENTS (see figures 1A, 1B, 1C, 1D, and 1E)

- A. Three to seven stories.
- B. 20' to 25' wide.
- C. 50' to 85' deep.
- D. Interior stairs to cellar (may have been removed if building has been renovated).
- E. Some form of light/air shaft may be provided. (see figure 1) These shafts are open at the top. The term "enclosed" as used in this bulletin will mean "a shaft open at the top and bound by building walls on all sides." Figure 1-B, 1-C, and 1-D show examples of enclosed shafts.
- F. Limited fire stopping.
- G. Combustible contents and structural components result in a hot smoky fire.
- H. The presence of *Energy Efficient Windows (EEW)* will further increase heat, gases and smoke conditions, possibly leading to a flashover or backdraft.

1.3 LIFE HAZARD

The combustible nature of the contents and structural components of these buildings coupled with the high population density in these areas confront the department with a serious life hazard. Occupants visible on arrival and in need of assistance, may be an indication of an even more serious life hazard elsewhere in the building.

Removal of trapped occupants from exterior locations has been covered in prior ladder company bulletins (#1 and #2) and should be accomplished without handicapping the interior operations of either ladder company. The absence of visibly distressed occupants shall in no way be taken as an implication that a tenement does not have a serious life hazard. Overcome, unaware, helpless or trapped occupants may be found anywhere on the fire floor or the floors above. A coordinated, concentrated team effort is required of both ladder companies to insure a proper, prompt search and removal of all endangered occupants.

1.4 VENTILATION

Saving life is the primary function of ladder companies. Any immediate, limited ventilation is justified if it is coordinated between the inside team and the outside team and it will help facilitate an interior search for occupants. Bear in mind that ventilation for search purposes will generally intensify the fire and could endanger other occupants of the building. The following principles of ventilation are of importance in carrying out assignments:

1.4.1 VERTICAL VENTILATION

This type of ventilation entails opening the bulkhead door and or roof scuttle and skylights.

This is the proven and accepted type of ventilation to be used in the initial stage of operations. It should be performed for the following reasons:

- A. Relieves the upper portions of the building of heat, smoke and gases. This prevents mushrooming and possible early extension of the fire. At the same time it increases the survival time of unconscious or trapped victims.
- B. Permits more thorough search and examination above the fire.
- C. Relieves public hall and stairs of smoke and heat aiding the escape of occupants.
- D. Relieves public hall and stairs of heat and smoke to allow an aggressive interior fire attack.
- E. Creates a vertical draft which channels the products of combustion, limiting horizontal spread and making control easier.
- F. Permits advance above the original fire area to search and cut off fire extension.

1.4.2 LATERAL VENTILATION (Horizontal)

This type of ventilation entails the opening or removal of the windows of the fire apartment or fire area in order to:

- A. Permit rapid advance of the attack line to the immediate fire area.
- B. Reduce danger of heat and or flame passing over or around the "attack line", since the smoke and heat are permitted to escape through these controlled openings.
- C. Make thorough search procedures easier on upper floors as well as on the fire floor.

NOTE: In A. and B. above. This lateral ventilation is usually affected after a charged line or lines are in position.

1.4.3 VENT FOR FIRE

Is accomplished to facilitate the Engine Company advance to, and extinguishment of, the fire. This venting is normally delayed until the Engine Company has its water, and is ready to "move in".

1.4.4 VENT FOR LIFE

Is accomplished to facilitate movement of members into an area where there is known or suspected life hazard. With an inherent calculated risk of eventually "pulling fire" it is performed as part of an attempt to reach possible survivors as soon as possible. These actions must be coordinated with the inside teams.

NOTE: LATERAL VENTILATION MUST BE COORDINATED BETWEEN THE INSIDE AND OUTSIDE TEAMS.

1.5 GENERAL AREAS OF RESPONSIBILITY.

1.5.1 FIRST LADDER COMPANY TO ARRIVE:

- A. Ladder company operations on fire floor.
- B. Determine life hazard and rescue as required.
- C. Roof ventilation and a visual check of rear and sides from this level.
- D. Laddering as needed.
- E. If second ladder company will not arrive within a reasonable time, make interior search and removal of endangered occupants above the fire.

1.5.2 SECOND LADDER COMPANY TO ARRIVE

- A. *All floors above the fire floor* for search, removal, ventilation and to check for fire extension.
- B. Confirm roof ventilation. (assist first unit)
- C. Check rear and sides of buildings.
- D. Reinforce laddering and removal operations when necessary.

1.6 SIZE UP

Is an ongoing evaluation of the problems confronted within a fire situation. Size up starts with the receipt of the alarm and continues until the fire is under control. This process may be carried out many times and by many different individuals during a fire.

1.6.1 The factors which all members must consider in size-up are:

- A. ***Time***
Governs the life hazard. Night fires mean poor visibility, buildings locked effecting delay in access. A tenement fire is more serious at night than in daytime.
- B. ***Life***
The most serious factor at any fire. What is the location of the life hazard in relation to the fire. Life hazard to firefighters must also be considered.
- C. ***Area***
Building or occupancy area. Large areas to be searched requiring search lines. Large areas generate fires of great intensity, heavy volumes of smoke and severe heat.
- D. ***Height***
Building height will govern the use of the Aerial and/or Tower Ladder and portable ladders.

- E. ***Construction***
Non fire proof, contains vertical voids that allows for extension. Alterations may have introduced larger voids, both vertical and horizontal. Wooden "I" beams, lightweight truss, *Energy Efficient Windows* and membrane roofs can effect the safety of operations within the structure. The presence of front or rear fire escapes or party balconies, will also have an effect on fireground operations.
- F. ***Occupancy***
This determines the severity of the life hazard and the intensity of the fire. *For example:* A commercial occupancy with an increased fire load on the first floor with apartments above.
- G. ***Location and Extent of Fire***
A fire in the cellar, shaft, or apartment on the top floor will determine access and areas to be searched.
- H. ***Water Supply***
Hydrant availability, and the placement and readiness of hoselines.
- I. ***Street Conditions***
Effect apparatus access and the placement of Aerial/Tower ladders to the fire building.
- J. ***Auxiliary Appliances***
Standpipe/sprinkler systems, and the location of outlets, O S & Y, and/or check valves.
- K. ***Weather***
Snow and freezing conditions, wind velocity and direction are major factors in safety and fire operations.
- L. ***Apparatus and Equipment***
Be aware of the units on the scene. The arrival of those units assigned on the alarm, Engines and Ladders, 1st due, 2nd due, etc..
- M. ***Exposures***
May be adjoining buildings or areas within the fire building itself (auto exposure). E.g., floor to floor via windows, and across shafts or adjoining apartments.

2. OPERATIONAL PLANS

2.1 DESCRIPTION

- 2.1.1 An operational plan is necessary and has to be formed before the fire. The plan must be understood by all and continual training is required. This bulletin presents such a plan. However, as in any operational plan it must be flexible. *For example:* There may be only one ladder company at the scene or the second unit may not arrive in time to operate according to the plan. Some minor adjustments may be required.
- 2.1.2 All ladder companies shall have a riding list posted conspicuously on the apparatus floor assigning positions and/or tools. This is in addition to the required riding list on the apparatus and in the officer's possession. All riding lists are generally prepared and predicated on the level of experience and training of the members working, their experience in the type of occupancies to which the unit responds the greatest number of times and where the greatest life hazard exists. The well trained unit should also have alternate tool assignments and/or positions when they are second to arrive or when operating in other types of dwellings.
- 2.1.3 Upon the receipt of an alarm, the information received shall be conveyed to all members. How the unit is assigned on the box, the address, apartment number and floor, type of dwelling, occupied or vacant. This information is vital to the size-up of the members responding.
- Any additional information including CIDS or that which is received while responding (such as persons trapped or instructions to have apparatus enter from a specific direction) must be relayed to all members.
- 2.1.4 When two ladder companies arrive at approximately the same time but out of response sequence, care must be exercised to avoid loss of efficiency due to uncertainty which may cause duplication or neglect of a duty assignment. They shall be guided by their alarm box assignment and operate in accordance with this bulletin. For this reason, the second due unit shall make no extraordinary effort to arrive at the location before the first due unit.
- 2.1.5 The following operational plan while designed for Old Law Tenements is equally effective in and should be used for New Law Tenements (even those with five to eight apartments to a floor). To apply the plan consider the vertical line of apartments in which the fire apartment is situated as if it were a similar section in an Old Law Tenement and operate the same way.
- 2.1.6 As some Ladder Companies are equipped with an apparatus that requires a tiller position, the term Outside Vent Position shall be interchangeable.

3. **APARTMENT FIRE**

ASSUMPTIONS:

There is a light to medium fire situation within the building with one or more rooms involved and both ladder companies and required engine companies will arrive at the scene.

Light Fire Situation.

"Indicates a fire which can be extinguished with the operation of 1 hand line and/or hand extinguishers or those that can be readily extinguished without resorting to extinguishing agents."

Medium Fire Situation.

"Indicates a fire which may be extinguished with the operation of 2 hand lines."

- 3.1 Ladder Companies will institute a two team offense that will cover their area of assigned responsibility.

INSIDE TEAM:

- A. Officer Position
- B. Forcible Entry Position
- C. Extinguisher Position

OUTSIDE TEAM:

- D. Chauffeur Position
- E. Outside Vent (OV) Position
- F. Roof Position

3.2 FIRST LADDER COMPANY TO ARRIVE

INSIDE TEAM

A. OFFICER POSITION (*First Ladder*)

TOOLS: H.T.
 Hand light
 Officers tool

POSITION:

The door to the fire apartment reached via the interior stairs of the fire building.

DUTIES:

1. Performing an immediate size-up and gives necessary orders.
2. Insure that entry doors at street level are chocked open, to enable the stretching of hand lines or access by other members.
3. Takes command of forcible entry, locating the fire, search and removal of victims.
4. Maintain control of fire apartment door.
5. A decision must be made whether entry into the fire apartment by the inside and outside team can be made safely before a charged line is in position.
6. Control the horizontal ventilation on the fire floor, by the inside and outside team.
7. Penetrate to the seat of the fire and try to contain it by shutting a door or using a portable extinguisher. A thorough primary search must be started at this point. Ventilate as required in order to conduct this search, keeping in mind that the fire can be drawn to the area vented. Verify that all areas of the fire apartment have been covered.
8. Inform the engine company officer of fire location and any unusual layout that will cause difficulty in reaching the fire. Provide and maintain an unobstructed path through which the hose line can advance. Furniture, appliances or other articles blocking the advance of the line, will have to be moved.
9. Be aware of structural features that would endanger exposures or permit extension, such as shafts, voids, etc.. Relay necessary information to the Incident Commander.
10. Be aware of and await return of members operating in other locations. Secure information regarding their observations and operations. If any member has not been accounted for in a reasonable time, take prompt action to locate him/her.

11. Company officers must maintain communication with members not operating under their immediate supervision to determine their status. The interval between contacts should be frequent enough to provide for the safety of the firefighter being monitored without monopolizing the H.T. frequency.

NOTE: Members are under the "Immediate Supervision" of an officer when:

- A. They are within sight and/or hearing of the officer.
 - B. They are working with a search line or hose line which is under the supervision of an officer.
12. Insure the safety of his/her members on the fire floor by close supervision. Prior training, combined with adequate communications and control on the fire ground is necessary for the safety of all members.
 13. Control operations on fire floor that will affect members operating on floor above. Be aware of changing conditions on the fire floor that could endanger units operating on the floors above.
 14. ***When necessary, ensure members are reminded of their designation as safety team members.***

B. FORCIBLE ENTRY POSITION (*First Ladder*)

TOOLS: Axe/Halligan (Maul/Halligan)
 Rabbit tool
 Flashlight
 H.T.*

POSITION:

Door to the fire apartment. Reached via the interior stairs of the fire building.

DUTIES:

1. Forcible entry.
2. Immediate search and removal of victims.
3. Locate the fire.
4. Ventilate as required and ordered.

C. EXTINGUISHER POSITION (*First Ladder*)

TOOLS: 6' Hook
 Pressurized water extinguisher
 Flashlight

POSITION:

Door to the fire apartment. Reached via the interior stairs of the fire building.

DUTIES:

1. Assist in forcible entry.
2. Search and removal of victims.
3. Locate the fire.
4. Use the extinguisher where it can be of any possible help.
5. Ventilate as required and ordered.

OUTSIDE TEAM

D. CHAUFFEUR POSITION (*First Ladder*)

The chauffeur must have a working knowledge of the duties and responsibilities of all members of first alarm ladder companies and how they are likely to execute their assignments under different fire situations. Monitoring the HT will be of assistance in making decisions. The chauffeur should have the ability to evaluate a problem and then make a sound decision to cope with it.

TOOLS: H.T.

Flashlight

The chauffeur shall select the tools that he/she deems necessary to complete his assignment.

POSITION:

The front of the fire building.

The chauffeur of an aerial ladder shall not operate in a manner that will in any way impede his/her return to the pedestal and cause a delay in positioning or repositioning the aerial for rescue or removal operations.

The chauffeur must notify his/her company officer of intended destination when leaving this primary position.

DUTIES:

1. Position apparatus for complete coverage and immediate use. If unable to attain this position the Incident Commander must be notified.
2. Raise and use aerial and/or portable ladders for rescue.
3. Roof access if necessary.
4. Vent the fire floor.
5. Ladder chauffeur should remain on turntable when members have entered the building by aerial ladder and are in precarious positions such as: a floor over a heavy fire, the roof of a building with a heavy fire condition etc.. The chauffeur should keep alert as to the who, when, where of members using the aerial ladder.
6. *If the chauffeur is aware that the 2nd ladder company is not in service or will not arrive in a reasonable time, he/she shall team up with another available member to try to get above the fire via aerial or portable ladder.*
7. *The chauffeur and OV's duties are complementary when the fire apartment and fire escape are located in the front of the building. For purposes of efficiency, the OV and Chauffeur shall team up while keeping in mind the necessity to be available for the use of the aerial or portable ladders to assist members in distress.*

8. A situation that can arise, is the obvious need to use the aerial for the roof firefighter but at the same time there is an apparent need to remove an occupant. Consider the following factors in reaching a decision as to its initial use:
 - a. *Emotional state of the occupant.*
An agitated, frightened occupant or one threatening to jump should be removed first.
 - b. *Fire/Smoke in the immediate vicinity of the occupant.*
The occupant must receive instant attention if he/she would be endangered or seriously disturbed by any delay in his/her removal.
 - c. *Location and severity of the fire.*
A rear first floor fire will not normally require immediate removal of occupants from the 3rd, 4th, or higher floors in the front of the building. Conversely, a fire on the upper floors rarely requires removal operations on lower floors.
 - d. *The Time Element.*
When aerial ladder is needed both for removal and roof access, roof access can be given priority if the person to be removed is in no immediate danger. *If any doubt exists remove the occupant first.* After roof access has been attained, the aerial ladder may be used for the removal, keeping in mind that the ladder must be repositioned as quickly as possible to avoid endangering the roof firefighter should the roof position become untenable.
9. When approaching the alarm location and there is no visible indication of fire, position apparatus so that it can be moved to provide maximum coverage if necessary.

E. OUTSIDE VENT POSITION (*First Ladder*)

- TOOLS: 6' hook
 Halligan tool
 Flashlight
 H.T.
 For top floor fires the saw is taken in place of the hook.

POSITION:

Except for assisting the chauffeur in front of the fire building when aerial or portable ladders are needed for rescue or removal, *assignment is to ventilate the fire area from the exterior providing lateral ventilation.* This is generally done from the fire escape landing of the fire apartments. Access is via the front or rear fire escape. Some buildings have one or two apartments per floor with one fire escape. In this case the OV's choice is eliminated and he/she uses that fire escape. Other buildings have three or four apartments per floor and the building will have both front and rear fire escapes. In this case he/she must choose the correct one to attain a position on the exterior of the fire floor. If the location of the fire apartment is not obvious from the exterior of the building the OV should communicate with his/her officer. Once the location is verified the OV can then reach the correct fire escape via a window from a lower or adjacent apartment or from a drop ladder/portable ladder at ground level. (see figures 3A & 3B)

Figure 3A

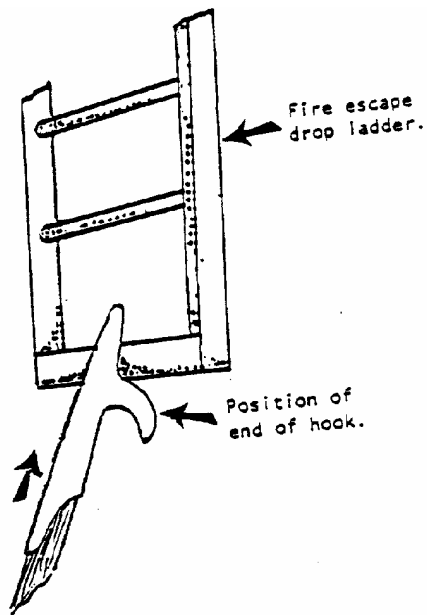
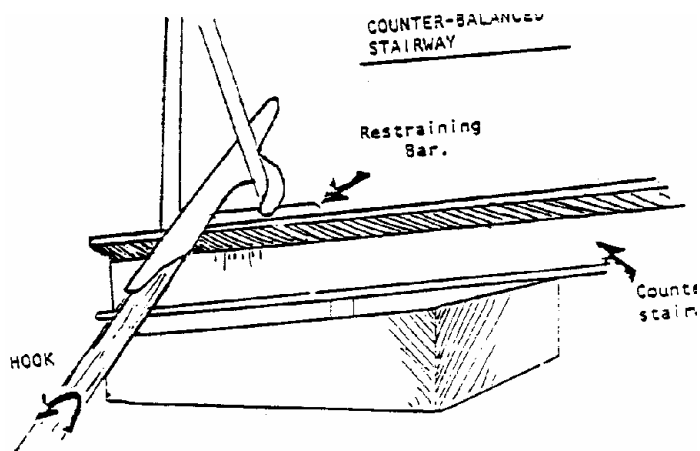

Figure 3B



THERE ARE OCCASIONS WHEN THE OV POSITION IS VARIED:

1. *Store Fire:*
Ventilate the rear of the store from the exterior. If this would expose people on a fire escape, ventilate immediately after they are out of danger. If a delay in ventilation is encountered and/or anticipated, notification should be made to your company officer.
2. *Top Floor Fire:*
Proceed to roof with saw and Halligan tool. If possible, descend fire escape and provide ventilation. Entry and search will be completed if he/she teams up with the 2nd OV (or another available member). If unable to descend the fire escape notify your company officer, attempt to vent fire apartment from roof level, and then assist the roof firefighter with roof vent.

DUTIES:

1. Assist in laddering for rescue work.
2. Lower fire escape drop ladder, or position a portable ladder.
3. *Vent for fire:*
Ventilate fire floor from exterior. The OV has the responsibility of timing the exterior ventilation with the advance of the charged handline. Communication with his/her company officer via handi-talkie must be maintained in order to coordinate and control lateral ventilation. Ventilation may be extremely difficult due to EEW's.
4. *Venting for life:*
Prior to venting from the fire escape, the OV must receive permission from his/her company officer via H.T.. The OV might not be aware of conditions in the apartment. Entry and search will be completed if he/she teams up as follows:
 - a. ***When there is only a rear fire escape (railroad apartments) OR the fire apartment is in the rear, the OV and Roof Firefighter (or another available member) shall team up and enter the fire apartment from that fire escape.***
 - b. ***When there is a front fire escape AND the fire apartment is in the front, the OV and Chauffeur (or another available member) shall team up and enter the fire apartment from that fire escape (see section 3.2.D.7).******In both situations, they will effect the removal of any occupants but still consider fire severity or extinguishing operations which may endanger them. This task may prove difficult due to bars and gates.***
5. When the OV must assist the chauffeur in a removal operation, or the OV is unable to descend the fire escape from the roof, the officer may dispatch a member of the forcible entry team to perform outside ventilation after they have forced the door to the fire apartment. ***Entry and search will be completed if he/she teams up with another available member.***

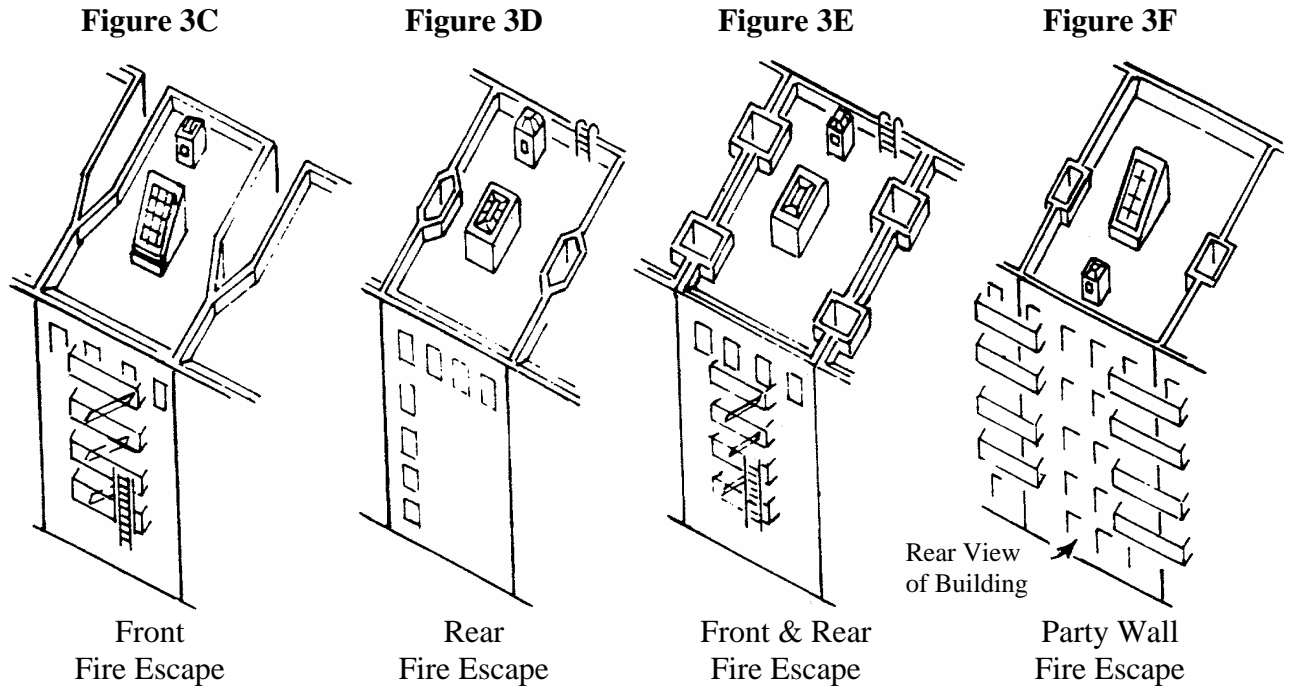

F. ROOF POSITION (*First Ladder*)

TOOLS: Halligan tool
 6 Halligan Hook
 Flashlight
 H.T.
 Life Saving Rope

POSITION:

Roof of fire building.

Roof ventilation is critical for search, rescue and extinguishment of the fire. *NOTHING SHALL DETER* the member assigned the roof position from carrying out the assigned duties. The duties of the roof firefighter demand an experienced, observant and determined member capable of decisive action.

ACCESS TO THE ROOF:

1. *Adjoining Building*
 Generally, there are contiguous buildings making this the safest and most dependable method. Be aware of possible extension of fire to exposures.
2. *Aerial Ladder*
 The aerial ladder is used when the building is isolated or the roof cannot be reached, or accessed from the adjoining building, due to a difference in height or obstructions caused by security barriers, fences etc.. Roof access from the aerial can be dangerous. The cornice slopes towards the roof and in some instances there is a high front parapet wall. Use caution stepping off the aerial, especially when visibility is poor.
3. *Rear Fire Escape*
 This access to roof is least desirable. It is only used when other means are not available and when the fire floor can be safely passed at this location. It is obviously dangerous to try to pass the fire floor when the fire is exposing the fire escape or is on the verge of venting itself in this direction. Rear fire escapes extend to the roof (figures 3D & 3E) unless of the party wall balcony type (figure 3F). Front fire escapes do not extend to the roof (figures 3C and 3E).

NOTE: The interior stairs are *NEVER* used for the following reasons:

- ◆ Danger of being trapped above the fire.
- ◆ Banked heat and smoke may prevent member from reaching roof.
- ◆ Will lead to a delay in roof ventilation when it proves dangerous or impractical.

DUTIES:

The duties of a roof firefighter demand an experienced, observant and determined firefighter capable of decisive action. The responsibility of this position covers three broad areas; life, communication, and ventilation. Roof ventilation is critical for search, rescue and extinguishment of the fire. ***NOTHING SHALL DETER the member assigned the roof position from carrying out the assigned duties.*** The roof firefighter should always confirm his/her way off the roof as soon as he/she reaches the roof. The roof firefighter is responsible for the following: (see figure 3G)

1. Opening the bulkhead door and skylight, or scuttle and roof level skylight over interior stairs.
2. Probing bulkhead landing for victims.
3. Probing for roof level skylight draft stop.
4. A perimeter search of the building for persons trapped and those who may have jumped or fallen. This search shall include the sides, rear and shafts of the building.
5. Locating the fire and making a visual check for extension across shafts or by auto exposure.
6. Transmitting vital information to the Incident Commander, either directly or through the company officer, on conditions observed from that vantage point.
7. ***When necessary, team up with the OV to VES the fire floor and, if not needed for search on that floor, proceed to VES the floors above the fire.***
8. ***When necessary, team up with 2nd Roof firefighter to VES all floors above the fire.***
9. At top floor fires, venting top floor windows from roof level. He/she is also ***RESPONSIBLE FOR UTILIZATION OF THE SAW*** to vent the cockloft and top floor when necessary ***AFTER COMPLETING INITIAL DUTIES.***
10. Conveying information to 2nd ladder company. Inform them of the extent of the search completed, so that all floors above the fire may receive a thorough search. Also inform the 2nd ladder company when proper examination of exposed interior stairs and public hall has not been made due to other duties. The 2nd ladder company shall complete the above mentioned examinations.
11. Reports back to their company officer (generally located on the fire floor) when assignment is completed or when relieved by 2nd ladder company and apprise them of all pertinent information.

NOTE: One of the greatest hazards is the possibility of fire cutting off the roof firefighters escape route. Conditions on the roof often change without warning, cutting off the initial access point. The roof firefighter must plan alternative routes, then continually monitor the fire and its effect on the alternatives for as long as he/she is on the roof

Figure 3G

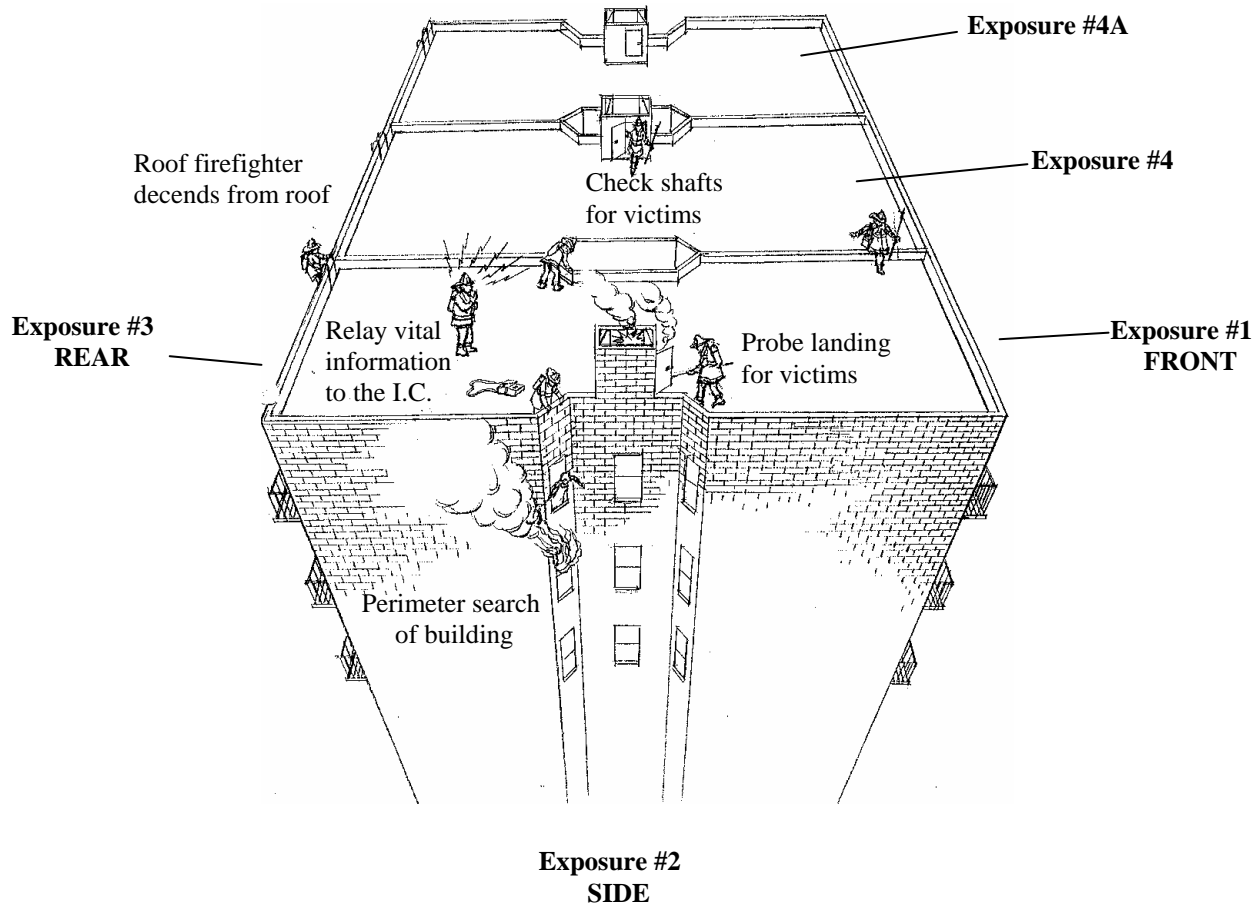

12. *Roof Ventilation*

Building will have either a bulkhead with a skylight or a scuttle with a roof level skylight over the interior stairs.

- a. **IF BUILDING HAS A BULKHEAD;**
Open bulkhead door. These doors are almost always self closing. To keep the door open, either remove the upper hinge or block the door open (figures 3H and 3I).

Figure 3H

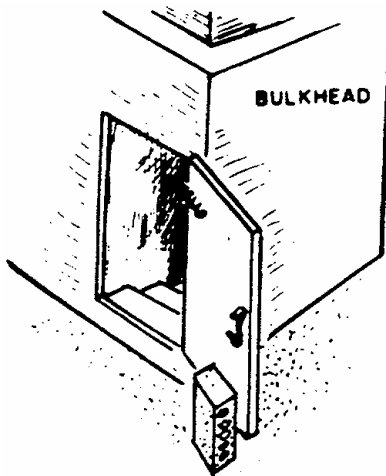
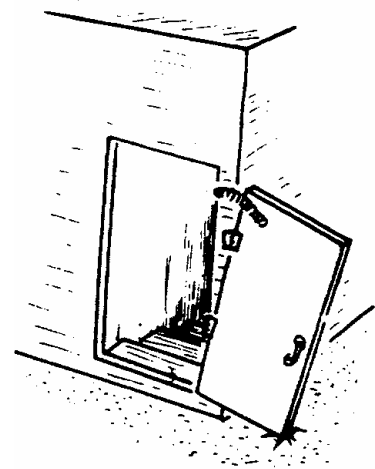
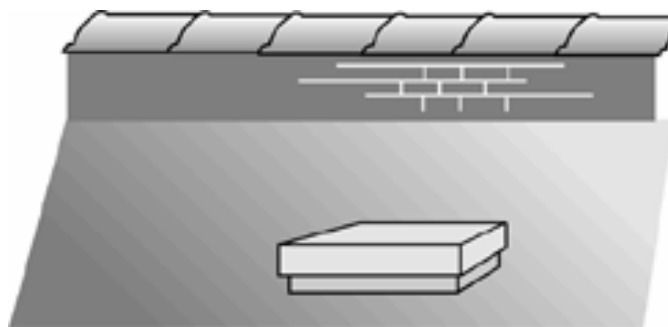

Figure 3I



- b. **IF BUILDING HAS A SCUTTLE COVER:**
Remove scuttle cover. This may be difficult because scuttle cover may be nailed down, have several coatings of tar at the seams and/or secured by hooks, chains, etc. on the underside of the cover.

Figure 3J



Scuttle Cover

- c. Heavy smoke and high heat issuing from the bulkhead doorway or scuttle would obviously require further ventilation such as removal of the skylight.

The absence of these indications does not necessarily mean that skylight ventilation is not required. Opening a bulkhead door or scuttle cover will not always give a true indication of interior fire conditions; the door to the fire apartment may not be open, either because it has not been forced or because it is being held in a closed position. Evaluate other factors (heavy smoke or fire showing from several windows, etc.) in determining the amount of ventilation that will be required when the door to the fire apartment is opened.

- d. Remove skylight over stair bulkhead (figures 3K, 3L) or on roof level. (figure 3M) If fire and smoke conditions are obviously heavy, immediate venting of the skylight prior to the removal of the scuttle cover to relieve the interior would be justified.

Figure 3K

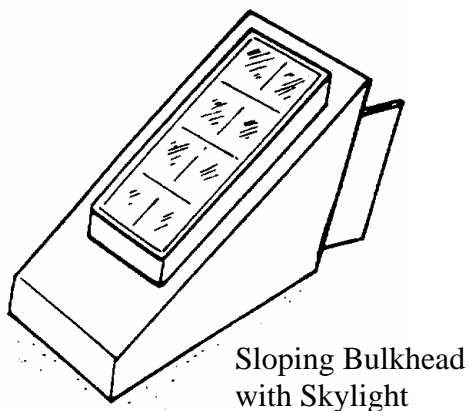

Figure 3L

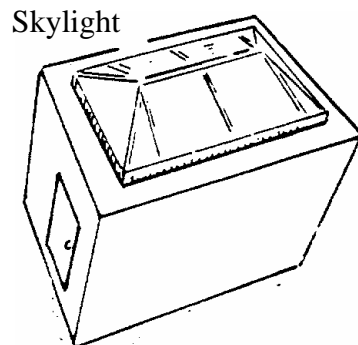
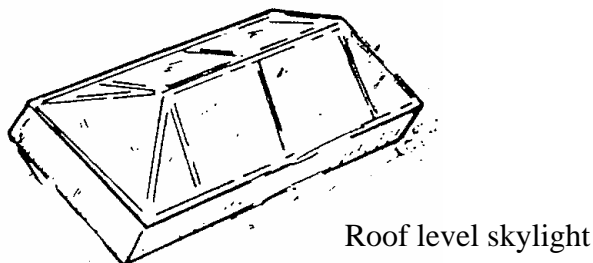

Figure 3M



- e. If difficulty is encountered opening the bulkhead door, vent the bulkhead skylight first. Units operating below shall be warned by H.T., prior to breaking glass. Pause after breaking the first pane, as this serves as a warning to members below and also allows roof person to determine the wind direction.
- f. Work with the wind at your back, when possible. When protective wire screens cover skylights insert tool beneath screen to remove glass.

NOTE: Skylights at roof level may have been removed and openings covered with roofing materials. It may be necessary to cut a hole over the stairs to vent stairway. The Incident Commander should be informed that a saw is needed to accomplish this.

- g. Remove skylights or coverings over all shafts if indicated by heavy heat and smoke conditions. This includes dumbwaiter shafts, light shafts, etc.. (figures 3N and 3O) To insure an unobstructed outlet for shafts other than dumbwaiter shafts, probe with hook to detect possible presence of a glazed sash or other covering and remove it.
- h. After removing roof level skylight or scuttle cover, returns can be opened into cockloft to gain knowledge of conditions or to ventilate. (see figure 3P)

Figure 3N

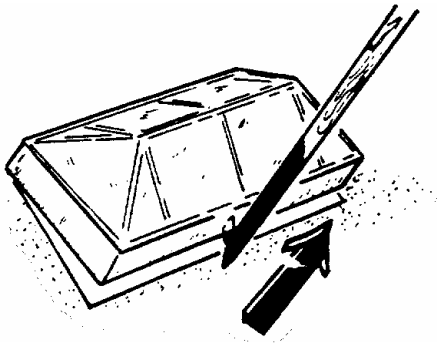
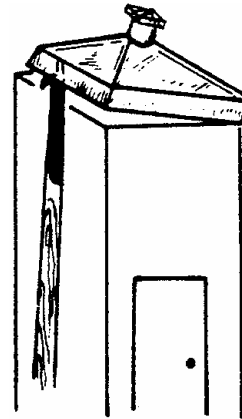
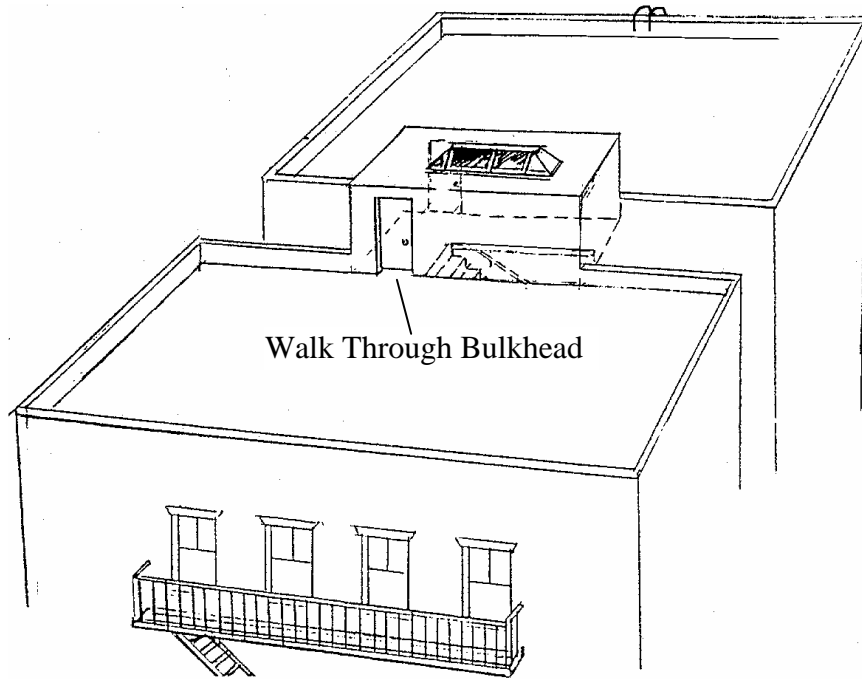

Figure 3-O



Dumbwaiter Bulkhead

Figure 3Q



13. *Walk Through Bulkhead*

A structure at the uppermost portion of interior stairs that may isolate the front section of the roof from the rear. One must walk through the bulkhead to reach the other section of the roof. (figure 3Q)

Figure 3P

Open returns to check for fire extension in the cockloft.

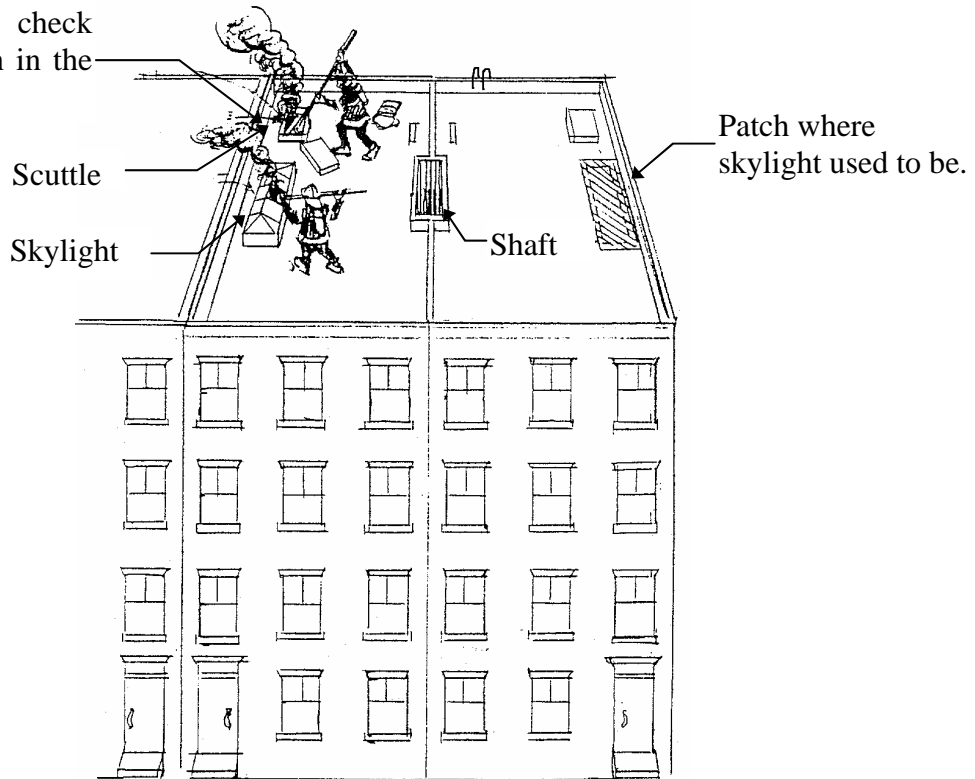

14. *Teaming up to vent and search*

- a. *After duties on the roof have been completed, the roof firefighter shall descend the rear fire escape to team up with the OV firefighter to VES.***
- b. *Where the fire is in the front of the building and there are three or four apartments on a floor, the OV and Chauffeur will be teamed up in the front of the building. In this situation, the roof firefighter can then team up with the 2nd roof firefighter to VES the floors above the fire using the rear fire escape. Pay particular attention to the top floor, especially the public hallways. THE PUBLIC HALL AND STAIRS, INCLUDING BULKHEAD LANDING ARE FREQUENTLY SEVERELY EXPOSED AND REQUIRE EXAMINATION FOR VICTIMS AS SOON AS POSSIBLE. The roof firefighters can get from the rear apartment to the front apartment using the public hall, or if necessary, open the common wall between apartments. When searching the floor above the fire, assist in venting the fire apartment by venting windows below with a tool.***
- c. *In either case, the company officer shall be notified when and where the search will commence.***

NOTE: Should a firefighter be caught in the public hall while moving from the rear to front apartment when the door to the fire apartment is opened below, he/she may be exposed to severe heat, smoke and flame, placing member in an extremely precarious position. In this event, drop to the floor and slide or roll to the nearest wall. This position places the member away from the rising column of heat and flame and increases the member's chance for survival. Following the initial release of heat and flame, the member may be able to move horizontally or vertically to a safer position or be assisted by members working below who have been alerted to his/her predicament. The less dangerous access may be breaching a wall between the front and rear apartments.

3.3 FIRST LADDER COMPANY TO ARRIVE (TOWER LADDER) Old Law Tenement No Front Fire Escape

TOWER LADDERS AND AERIAL LADDERS SHALL OPERATE THE SAME EXCEPT:

INSIDE TEAM:

Tools, Position, and duties remain the same. *If necessary, the Officer may dispatch a member of the forcible entry team to team up with the roof firefighter after they have forced the door to the apartment.*

OUTSIDE TEAM:

Tools, position, and duties remain the same with the following exceptions:

CHAUFFEUR:

Position- Remain at pedestal for overall safety, control, and coordination.

OUTSIDE VENT:

Position- Operates as basket firefighter for *ventilation*.

ROOF:

Position- Roof of fire building.

Duties- *Roof operations remain the same as in 3.2 F*

If necessary, the officer may request the Roof firefighter to perform outside ventilation of the fire apartment from the fire escape after completion of preliminary roof ventilation (bulkhead, scuttle, skylight). He/she proceeds via the fire escape to the fire floor to perform ventilation. If entry and search is to be made, he/she shall be teamed up with one of the following:

- ◆ *2nd Roof firefighter*
- ◆ *a member of the forcible entry team*
- ◆ *another available member*

NOTES:

1. The second ladder must be aware when VES on the upper floors has not yet been performed.
2. If additional manpower available, they should be assigned to the Tower Ladder as the 6th firefighter.

3.4 SECOND LADDER COMPANY TO ARRIVE

Units responding to any fire should monitor both the department radio and Handie-Talkies. This will provide members with vital information about conditions at the scene and make them aware of problems encountered by first arriving units, such as water supply problems, people trapped, location and severity of fire, heavy smoke condition, apparatus blocked out of street etc..

INSIDE TEAM

A. OFFICER POSITION (*Second Ladder*)

TOOLS: H.T.
 Hand light
 Officer tool

POSITION:

The door of the apartment directly over the fire apartment as this is generally the most serious exposure. The second ladder inside team is assigned an extremely difficult position in the apartment over the fire.

PRIOR TO PROCEEDING ABOVE THE FIRE, THE SECOND ARRIVING OFFICER MUST INSURE THAT THE OFFICERS ON THE FIRE FLOOR ARE MADE AWARE OF THIS TEAMS INTENTION, SO THAT MEMBERS OPERATING ABOVE CAN BE WARNED OF ANY SITUATION NECESSITATING WITHDRAWAL.

WHEN OPERATING ON THE FLOORS ABOVE THE FIRE, MEMBERS SHOULD FORCE ONE OR MORE DOORS ON EACH FLOOR TO PROVIDE AN AREA OF REFUGE.

DUTIES:

1. *BEFORE PROCEEDING ABOVE, THE OFFICER MUST SIZE UP CONDITIONS ON THE FIRE FLOOR. THE FOLLOWING SHOULD BE CONSIDERED:*
 - a. Severity and location of fire.
 - b. Line placement and availability of water.
 - c. Control of fire apartment door.
 - d. Consideration of an area of refuge before going above.
2. Direct forcible entry.
3. Direct search for victims and fire extension.
Be certain to check adjoining apartment on floor above the fire apartment. This may be even more severely exposed than the apartment directly over the fire apartment due to the construction of Old Law Tenements.
4. Call for a line if needed.
5. Cause a thorough search on all floors above the fire.
6. Have subordinates verify that areas assigned for search have been completely covered.
7. *DIRECT AND CONTROL VENTILATION.*
8. Insure that the rear and sides of the building are checked.
9. Assure safety of members.
10. Transmit necessary information to the Incident Commander.

B. FORCIBLE ENTRY POSITION (*Second Ladder*)

TOOLS: Axe/Halligan (Maul/Halligan)
 Rabbit tool
 Flashlight
 H.T.*
 *In some areas H.T.is assigned to this member.

POSITION:

The door of the apartment directly over the fire apartment which is reached via the interior stairs of the fire building.

WHEN OPERATING ON THE FLOORS ABOVE THE FIRE, MEMBERS SHOULD FORCE ONE OR MORE DOORS ON EACH FLOOR TO PROVIDE AN AREA OF REFUGE.

DUTIES:

1. Forcible entry.
2. Search for and remove victims.
3. Ventilate as required and ordered.
4. Make detailed examination for extension of fire. Feel baseboards, walls, etc..

C. EXTINGUISHER POSITION (*Second Ladder*)

Identification remains the same as for 1st ladder company for the sake of uniformity.

TOOLS: 6' hook.
 Flashlight
 Pressurized Water Extinguisher

NOTE: For top floor fires he/she should take two 6` hooks in lieu of the pressurized water extinguisher.

POSITION:

The door to the apartment directly over the fire apartment which is reached via the interior stairs of the fire building.

WHEN OPERATING ON THE FLOORS ABOVE THE FIRE, MEMBERS SHOULD FORCE ONE OR MORE DOORS ON EACH FLOOR TO PROVIDE AN AREA OF REFUGE.

DUTIES:

1. Assist forcible entry.
2. Search for and remove victims.
3. Ventilate as required and ordered.
4. Make detailed examination for extension of fire. Feel baseboards, walls, etc..

OUTSIDE TEAM

D. CHAUFFEUR POSITION (*Second Ladder*)

TOOLS: H.T.
Flashlight
The chauffeur shall select the tools he/she deems necessary to complete the assignment.

POSITION:

The front of the fire building. *If not needed here, then go above the fire if teamed with the 2nd OV (or another available member).*

DUTIES:

1. If possible, position apparatus to cover fire building.
2. Be alert to the possibility that the first to arrive ladder company may be blocked out. In this instance, if this position is not covered, the Incident Commander must be notified.
3. Assist laddering with 1st to arrive ladder company, if required.
4. ***Ventilate and search if teamed up with the 2nd OV (or another available member).***
5. Be ready to use an aerial or portable ladder to remove members or civilians in distress.

E. OUTSIDE VENT POSITION (*Second Ladder*)

TOOLS: 6` Hook
Halligan
Flashlight
H.T.

POSITION:

Above the fire unless needed for laddering, rescue, etc. Access is via fire escape, ladder, or adjoining building. Buildings equipped with party wall balconies, access is via ladder or adjoining building. All of this is determined by the physical characteristics of the building, location of the fire, extent and severity of the fire.

DUTIES:

1. Assist with laddering where necessary.
2. ***Search for victims and fire extension on all floors above the fire if teamed with another member.***
3. ***Vent for fire:***
Ventilate floor above fire floor from exterior. Communication with his/her company officer via handi-talkie should be maintained in order to coordinate and control lateral ventilation.
4. ***Venting for life:***
Prior to venting from the fire escape, the 2nd OV must receive permission from his/her company officer via H.T.. The 2nd OV might not be aware of conditions in the apartment directly over the fire. Entry and search will be completed if he/she teams up as follows:
 - a. ***When there is only a rear fire escape (railroad apartments) OR the fire apartment is in the rear, the 2nd OV and 2nd Roof Firefighter (or another available member) shall team up and enter the apartment directly over the fire from that fire escape.***
 - b. ***When there is a front fire escape AND the fire apartment is in the front, the 2nd OV and 2nd Chauffeur (or another available member) shall team up and enter the apartment directly over the fire from that fire escape. (see section 3.2.D.7)***

In both situations, they will effect the removal of any occupants but still consider fire severity or extinguishing operations which may endanger them. This task may prove difficult due to bars and gates.
5. After contacting his/her officer, ventilate the apartment directly over the fire apartment. Ventilation may be extremely difficult due to the presence of energy efficient windows. (EEW)
6. ***When the 2nd OV ventilates the apartment that his/her inside team is working in, he/she may speed up their search in this extremely exposed apartment by moving into it from the fire escape if teamed up with another available member and conditions permit.***

F. ROOF POSITION (*Second Ladder*)

TOOLS: 6' Halligan Hook
Halligan
Flashlight
H.T.

For top floor fires the saw and the 6' Halligan Hook are taken.

POSITION:

Roof of fire building.

1. Make a size-up.
2. Contact 1st to arrive roof firefighter to determine the following:
 - a. His/her method of access to the roof.
 - b. Problems encountered if any.
 - c. Need for assistance.
 - d. Need to seek an alternative route.

DUTIES:

1. Assist and confirm all duties of the 1st to arrive roof firefighter have been completed. Must team up with another member for efficiency and safety.
2. ***When necessary, team up with the 1st Roof firefighter or 2nd OV (or another available member) to search and ventilate all floors above the fire. Remove victims. Pay particular attention to top floor apartments, including the public hall.***

3.5 SECOND LADDER COMPANY TO ARRIVE

OPERATIONAL VARIATIONS (Fires Involving Top Floor and/or Cockloft)

A. DESCRIPTION

In general, top floor fires involving the cockloft result in a heavy smoke condition in all apartments on the top floor, necessitating entry and search for victims and/or extension of fire. Five firefighter staffing in ladder companies requires that the first to arrive ladder company operates with 3 firefighters (Officer and F.E. team) on the fire floor initially. It is obvious that more help is required on the fire floor. *The survival time of victims requires a quick search* of all apartments and if the first to arrive ladder company experiences forcible entry problems at the fire apartment, (numerous locks, police locks, etc.) valuable time is lost.

B. OPERATIONS:

1. *Inside team*

Proceed to the top floor to assist first ladder company in entry and search of all top floor apartments. This permits deployment of 6 firefighters (2 officers and 4 firefighters) in a critical top floor area.

2. *Outside Team*

a. ROOF POSITION

PROCEED TO ROOF WITH POWER SAW. Assist first to arrive ladder on venting roof and top floor windows, commence opening with saw if required.

- b. *OV POSITION***
VENT THE FIRE APARTMENT FROM THE FIRE ESCAPE. Lateral ventilation must be coordinated between the inside and outside team. If the 1st OV has already vented the fire apartment, then the 2nd OV will vent the adjoining apartment. If entering any apartment to search, they shall team up with each other (or an available member). This position is reached via the fire escape from below.
- c. CHAUFFEUR POSITION**
Front of fire building. If not needed here, proceeds to the roof.
1. Assist 1st to arrive ladder company with laddering if required.
 2. Assist in vertical and horizontal ventilation.
 3. Other duties as directed by company officer.

NOTES:

1. The critical need for additional members on the top floor is increased when the fire building is a New Law Tenement or other variation due to the large number of apartments and the possibility of extension into the adjoining wing.
2. Depending on severity of fire condition, if difficulty is experienced when venting windows from the roof level, it may be necessary to cut a ventilation hole in the roof before completion of horizontal ventilation.
3. When encountering membrane roofs, the Incident Commander must be notified because the volatility of this roof material may require a line to protect members operating on the roof.

4. SHAFT AND DUMBWAITER FIRES

4.1 GENERAL

LIGHT AND AIR SHAFTS

Between Old Law Tenements, either the enclosed or open end type, present a severe exposure hazard to exposed buildings.

(see figures 4A to 4D)

Light and air shafts can also be found within or between apartments, and can result in extension to one or more apartments on the fire floor or floors above.

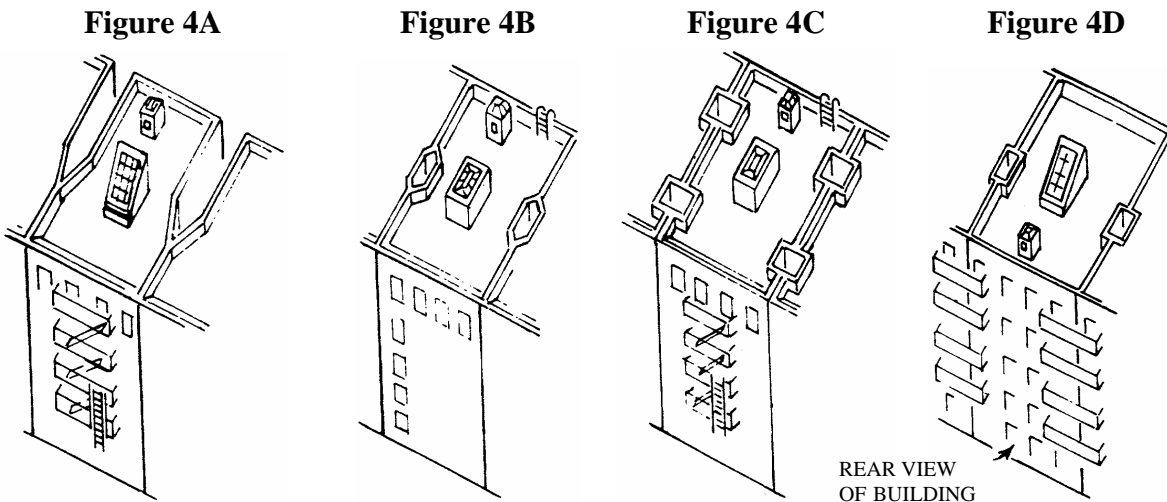

DUMBWAITER SHAFTS

Although the use of dumbwaiters has been discontinued in most buildings, these shafts still exist and present a serious potential for vertical and lateral extension of fire. These shafts may extend from the basement to above the roof and may contain electrical wiring, plumbing, compactor chutes, pantry closets, etc. which may allow fire to extend both vertically and laterally. Since some shafts served more than one apartment per floor, each apartment needs to be checked for fire extension. When a cellar fire exposes a dumbwaiter, all floors above must be checked for fire extension.

Figure 4E

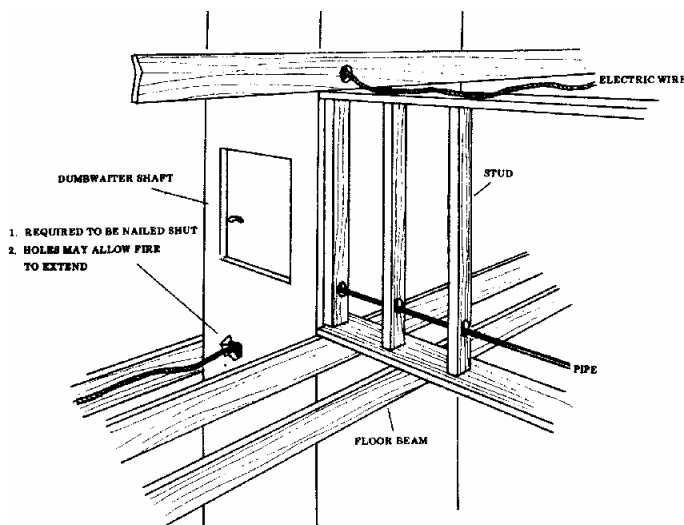

4.2 AIR AND LIGHT SHAFT FIRES

In recent years, due to inspection activities, shaft fires have originated much more frequently in an apartment than at the base of an open shaft. As the original fire room in the fire apartment may have been one, two or even three rooms away from the shaft, the conditions on the fire and floors above will approximate those found in the average tenement fire.

During the initial stages of a shaft fire, the window frames, curtains, drapes, etc., in both buildings feed the fire in the shaft. However, in most cases the draft created in the shaft will delay lateral extension in the apartments in the exposed building allowing time for occupants to use one of their means of egress or for members to find and remove them. Therefore, assuming a shaft fire originated in an occupied Old Law Tenement, the extreme life hazard on the fire floor and floors above demands immediate forcible entry, search, removal and control of these operations at these locations in the fire building.

The exposed building must be handled without detracting from our initial concentration on the two critical floors (fire floor and floor above) in the fire building.

The occupants of the fire building have less survival time and are in greater danger of having both means of egress quickly cut off than those in the exposure. When delayed alarms allow fire of unusual severity to communicate to shafts, lateral extension may be accelerated depending on the size of the shaft and its ability to remove the large amount of heat being generated. Under these conditions, time for evacuation of exposed buildings will be reduced. Increased attention to life safety will be needed. *THIS REQUIRES THE PROMPT CALLING FOR ADDITIONAL HELP.*

The following operational plan is formulated with the foregoing in mind:

4.2.1 OPERATIONAL PLAN

The plan, except for a few modifications, remains the same as the apartment fire operation. When operating either in the fire building or the exposed building, members should reduce the exposure hazard by closing windows on the shaft and by removing combustible hangings such as drapes, shades, curtains, etc., on and around these windows. The draft created by a shaft fire reduces the lateral extension during the initial stages, frequently permitting a close approach to the shaft on most floors. While awaiting hoselines, members may, by the proper application of water with pots, pans, etc., either extinguish fire around shaft windows or delay the lateral extension. As the apartments on the shaft are in the same line, it may be easier to use the fire escape of one apartment for access to the others than to force doors on several floors. When using fire escapes, exercise extreme caution, because these buildings are over ninety years old and their condition may have deteriorated.

A. 1ST LADDER COMPANY TO ARRIVE

Assignments remain the same.

In addition to their duties in the fire apartment, the officer and forcible entry team must facilitate the engine company's advance. The engine company, after controlling fire in a room exposing the shaft, must direct the nozzle stream into the shaft and control the shaft fire before continuing through the apartment for final extinguishment. To allow the engine to control the shaft fire before moving into other rooms, it may be necessary to close a door leading to an involved room.

B. 2ND LADDER COMPANY TO ARRIVE

Inside Team

Assignments remain the same.

Chauffeur

Position the apparatus to cover the exposed building. Operate as per section 3.4 or 3.5. If not needed in the fire building, then he/she is available for work in the exposed building.

OV

Operate as per section 3.4 or 3.5. If not needed in the fire building, then he/she is available for work in the exposed building.

Roof Firefighter

Operate as per section 3.4 or 3.5. If not needed in the fire building, then he/she is available for work in the exposed building.

Note: If exposed building is an IDLH area then members shall team up before entering exposures.

4.2.2 VARIATIONS

There are situations in which the same concentration of ladder company personnel in one building is not required. In these situations, the major effort will be where the life and fire extension hazard is the greatest.

- A. Fire originated in an apartment in a vacant building and exposing an occupied building.
- B. Shaft fire between two vacant buildings.
- C. Fire originated in the bottom of the shaft.

4.3 OPERATIONS: DUMBWAITER FIRES

FIRST AND SECOND DUE LADDER COMPANY ASSIGNMENTS REMAIN THE SAME:

- 4.3.1 All units must be immediately notified of a dumbwaiter fire.
- 4.3.2 It is important that the top floor, cockloft and cellar are checked as soon as possible.
- 4.3.3 If heavy smoke is venting out of a dumbwaiter bulkhead, the roof firefighter should inform his/her officer.
- 4.3.4 If fire is reported in the dumbwaiter shaft, the roof firefighter should vent the dumbwaiter bulkhead.
- 4.3.5 Similarly if after venting a dumbwaiter bulkhead, the roof firefighter does not see any appreciable volume of smoke venting, the roof firefighter should notify his/her officer. This may indicate there is an obstruction in the shaft below.
- 4.3.6 If dumbwaiter bulkhead has been previously removed and tarred over, the roof firefighter should notify his/her officer. This could result in rapid extension to the cockloft.
- 4.3.7 Members should not place any part of their body in the shaft. In most cases these shafts are not in use, but they still may contain heavy objects not substantially secured that may fall through the shaft, such as pulleys, mechanisms, etc..

5.0 OPERATIONAL TECHNIQUES AND USE OF TOOLS

5.1 ROOF HAZARDS

- ◆ Open shafts
- ◆ Soil pipes
- ◆ Clotheslines
- ◆ Sloping cornices
- ◆ Walk Through Bulkhead (see figure 3Q)
- ◆ Fencing
- ◆ Dogs
- ◆ Roof level skylights covered with substandard material
- ◆ High free standing walls around perimeter of building commonly found in renovated buildings
- ◆ Low or no parapet wall
- ◆ TV and radio antennas
- ◆ Sloping roofs
- ◆ High bulkheads
- ◆ Razor wire/barbed wire
- ◆ Membrane roof coverings
- ◆ Penthouse structures
- ◆ High cornices making access from aerial ladder dangerous
- ◆ Increased difficulties caused by rain, snow and ice.

5.2 MANEUVERING ON THE ROOF

Upon reaching the roof, your first question should be:

HOW CAN I MAINTAIN MY MEANS OF EGRESS

- 5.2.1 One of the greatest hazards is the possibility of fire cutting off the escape route. Conditions on the roof often change without warning, cutting off the initial access point. The roof firefighter must plan alternative routes, then continually monitor the fire and its effect on the alternatives for as long as the firefighter is on the roof.
- 5.2.2 THE FRONTS OF BUILDINGS ARE ALIGNED, BUILDING DEPTHS MAY VARY, AND OPENED END SHAFTS ARE GENERALLY LOCATED TOWARD THE REAR. (SEE FIGURE 5A) Therefore, if possible, the firefighter moves from one roof to another near the front wall always checking his/her footing as described below. In order to alert members to the presence of openings, roof level skylights and/or scuttle covers if removed, should be placed upside down on the roof. A firefighter encountering an inverted skylight or scuttle must anticipate the opening it previously covered.
- 5.2.3 Before walking or moving on a roof when visibility is poor, or a heavy smoke condition exists, firefighters should crouch to a kneeling position. Members should probe the roof surface by either swinging a tool or leg in the direction of movement. This is done to note the stability of the roof surface and to determine the presence of holes, shafts and other unobstructed openings. Members operating on the roof should not step over a parapet or wall without first feeling the adjoining surface with a tool. When momentarily blinded by smoke or darkness, and there is no immediate danger to the firefighter, it may be best for the member to remain in place until visibility is restored.

Figure 5A

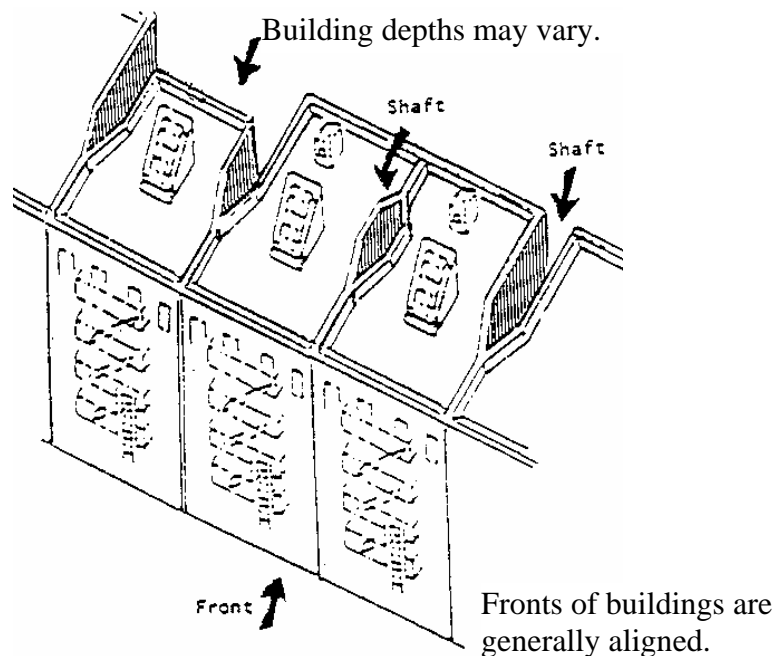

5.3 TOOLS FOR THE ROOF

The 6' Halligan hook and Halligan tool

A. THE 6' HALLIGAN HOOK

Figure 5B

Avoid standing directly
above window

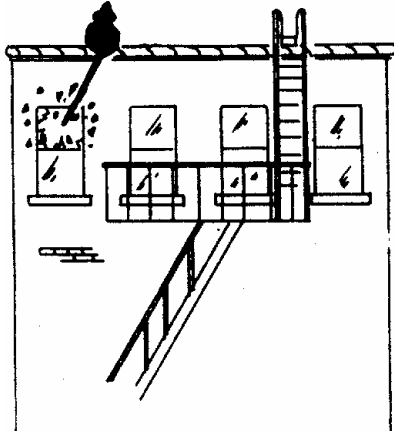
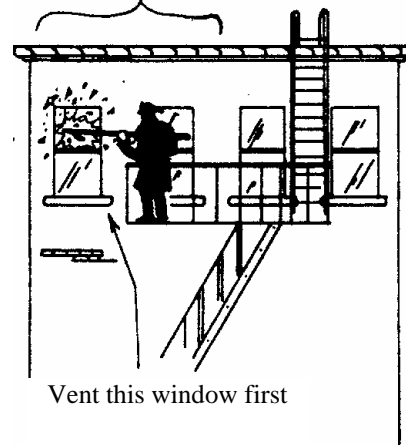

Figure 5C

Apartment to be Vented



1. For ventilating or removing skylights and probing where necessary.
2. For ventilating windows from above. (figure 5B)
3. For ventilating from a fire escape. (figure 5C)

B. THE HALLIGAN TOOL

1. To loosen bulkhead door from the upper hinge, or to remove the door entirely. (figures 5D and 5E)
 - a. To loosen the door from the upper hinge, open the door slightly and put the fork end of the tool between the door and the door jamb. Close the door on the tool loosening hinge screws, or,
 - b. Open the door slightly and put the adz end of the tool between the door and the door jamb. Apply pressure with the tool as shown in figure 5E.
 - c. To remove the door entirely, free both hinges and free the self closing device.
 - d. In the foregoing, operate from the roof side of the door and use the door as a shield against heat from the interior.
2. To open windows to gain access from the fire escape. (figure 5F)

3. To remove metal gates often found on fire escape windows. (Figure 5G)
 - a. These gates are always on the room side of the window and will first require opening or removing the window. Use either the fork or adz end of the tool to pull the gate loose at the side opposite the locking device. The gate is attached to the window frame with wood screws.
 - b. If severely exposed to heat or smoke at this side of the gate, removal may be accomplished at the lock side.

Figure 5D

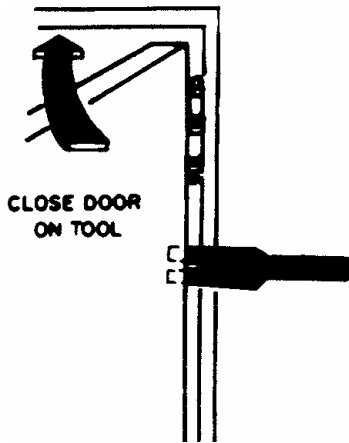

Figure 5E

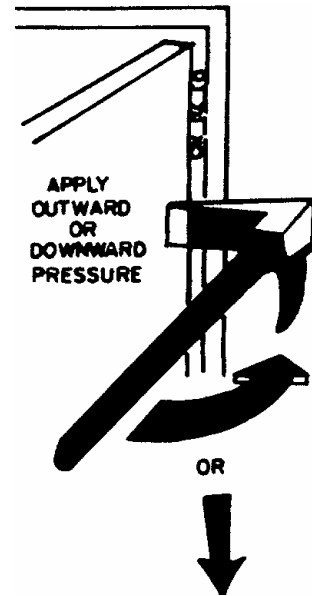

Figure 5F

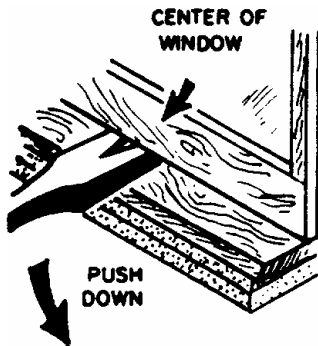
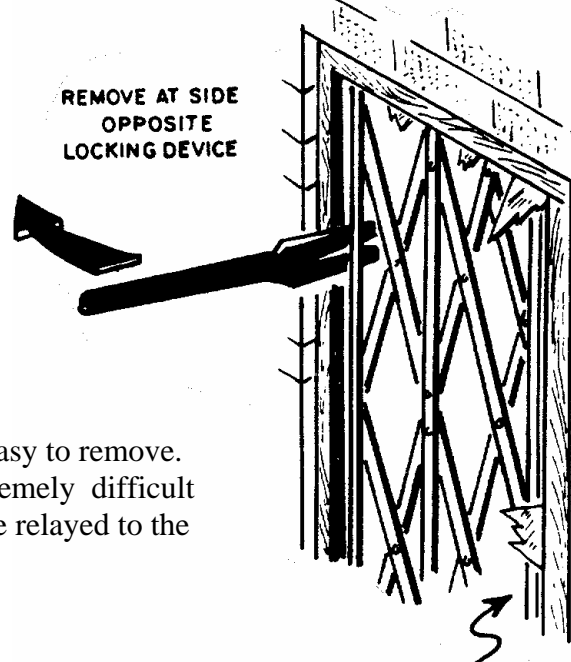

Figure 5G



NOTE: Newer style gates may not be as easy to remove. Formidable mounting may be extremely difficult to force. This information must be relayed to the inside team.

C. SPECIAL USES OF THESE TOOLS.

1. Use both to assist climbing onto a high bulkhead when alone. (figure 5H) The Halligan is placed with the fork end down and the adz end up. When coping is present remove a piece and hang the hook on the bulkhead's edge. Using the 6" hook to support most of your weight, step on the adz end of the Halligan and pull yourself up. While climbing the hook, exert a downward pressure and do not push against the wall with your feet. This lateral pressure may cause the hook to slip off the bulkhead wall. The intent is to enable the roof firefighter to reach the top of the bulkhead with both hands. Once this is achieved, he/she should be able to work themselves up onto the bulkhead. NEVER attempt to climb onto a bulkhead at a spot near or next to an open shaft or near a building wall that faces on a shaft, areaway or courtyard. (figure 5J)
2. Use removed door in conjunction with the Halligan to gain access to the roof of a bulkhead. Drive the hook of the Halligan into the roof. Then position the door against the bulkhead at an angle of 30 to 45 degrees with the roof. The Halligan serves as a stop and should be at a sufficient distance from the bulkhead to permit the proper angle. The door can be used as a ramp. The Halligan should be parallel to the bottom of the door for safety reasons. (figure 5I)

Figure 5H

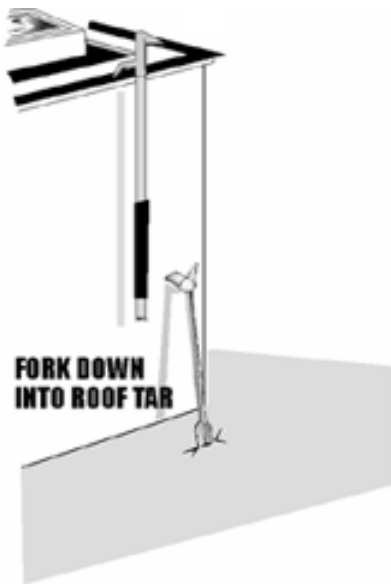
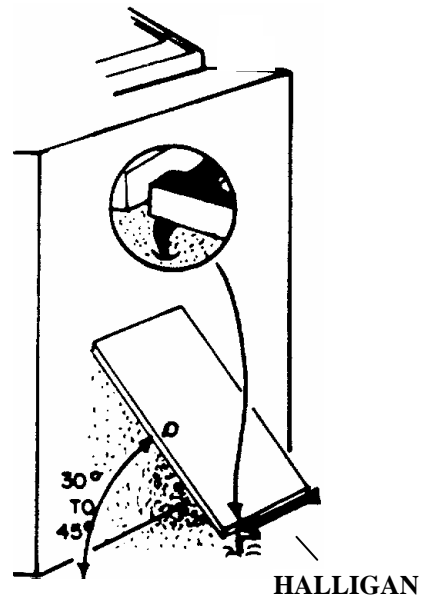
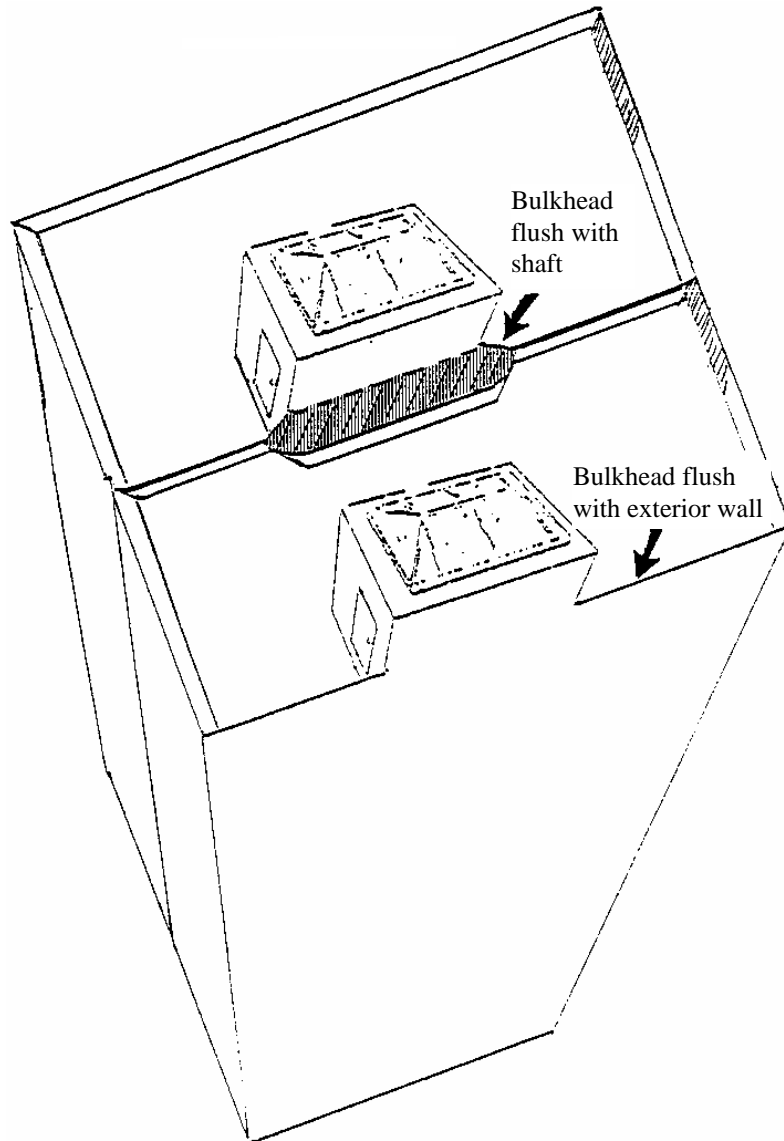

Figure 5I



After gaining access to and venting a high bulkhead, the fire firefighter should get off the same place where he/she gained access. This allows the firefighter to descend at a location that he/she is familiar with. *Some bulkheads are erected flush with an exterior wall (i.e., one side of the bulkhead is a continuation of a building).* This reduces the selection of an egress from the bulkhead. If in doubt the firefighter may drop an object (a tool if necessary) and listen for the sound of it hitting the roof surface. (see figure 5J)

Figure 5J
Venting a Bulkhead



3. Difficult bulkhead doors that are fastened on the inside.
Even if these doors are tight against the door jamb there will usually be enough space between the bottom of the door and the sill to get a purchase. The bottom of the door is pulled outward. Alternately using the Halligan tool and the hook, the firefighter works upwards until the adz or fork end of the Halligan is near the fastening. Prying out will break or dislodge the fastening. In this operation the hook is not used for prying, but merely to hold the advantage obtained, enabling the Halligan tool to be shifted to a new position. (figure 5K)

Figure 5K

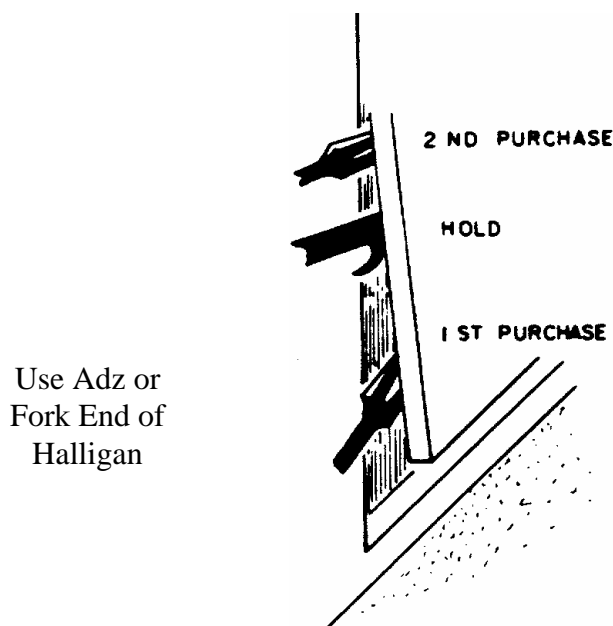

4. When pushing down the ceiling from the roof, reverse the hook because BX wires may snag the hook end.

5.4 FEATURES AND CONDITIONS INFLUENCING OPERATIONS

5.4.1 SIZE UP EXTERNAL FEATURES

A quick visual check should be made by all ladder company personnel as they approach the fire building. No time is lost and the information so obtained will undoubtedly increase the efficiency of the unit. Take note of:

- ◆ Visible life hazard
- ◆ Height in stories
- ◆ Adjoining Buildings
- ◆ Location of fire floor and fire
- ◆ Number of windows on each floor in front of the building
- ◆ Party balconies
- ◆ Fire escapes

Most OLT's are over 90 years old. During this time the fire escapes have been constantly exposed to the elements. They shall be used with extreme caution.

1. When the building has four (4) windows per floor and no front fire escape, it indicates two (2) railroad flats (Old Law Tenement) with a rear fire escape. (see figure 5L) This does not necessarily apply to a corner building.
2. When the building has four (4) windows per floor and a front fire escape, it usually indicates three (3) or four (4) apartments per floor with another fire escape in the rear. (see figure 5M)
3. The ever dangerous exception to this are those buildings with railroad flats whose secondary means of egress is a front fire escape. ***THE ABSENCE OF A REAR FIRE ESCAPE IS OF MAJOR CONCERN FOR THE SAFETY OF THE OPERATING FORCES. THIS INFORMATION SHOULD BE RELAYED IMMEDIATELY.*** (see figure 5N)



5.4.2 INTERIOR SIZE UP

Inside team will gain important operational information by observation. In addition to observing the fire escape situation described above, they can generally determine the number of apartments per floor by:

- A. Counting the number of mail boxes on each wall of the building entrance hall. This can be done with a glance and no waste of time. *For example:* five mail boxes on each side in a five story building would mean railroad flats. Likewise, ten on each side would mean four apartments per floor. A glance at both sides is necessary as occasionally all mail boxes will be on one wall.
- B. The apartment numbering and lettering system is also an indicator. Apartments designated 1S and 1N or 1W and 1E on the first floor and 2S and 2N or 2W and 2E on the second floor, will generally mean two apartments per floor. Any other numbering or lettering system frequently indicates more than two apartments per floor.
- C. Most Old Law Tenements have four doors on each floor, but this is not always an indication that there are four apartments. (*When forcing entrance to an apartment with two doors, choose the door normally used for entrance.*) Choosing the other door might result in a time delay because of furniture placement or the manner in which the door is secured (nailed, bolted etc.). Most railroad flats have the kitchen in the rear so that normal entrance doors will be the rear doors. On occasion the life hazard and/or location of the fire would dictate advancing the line through the other door; this situation would involve close coordination with the engine company.

5.4.3 ROOF LEVEL SIZE-UP

- A. Smoke may be seen issuing from the cornice upon arrival. Without investigation this cannot be taken as positive evidence that there is actually fire in the cockloft. The tin facing is loose fitting and the smoke readily shows at these openings. The only valid conclusion that can be drawn is that smoke and heat are entering the cockloft. Under no conditions should the cornice be opened for smoke. If still doubtful about the existence of fire in the cornice or cockloft, it can be examined by opening the ceiling below, or opening the returns if present. This is a quicker and easier operation than opening the roof. Roof openings to relieve fire conditions in cockloft or top floor should be cut directly over the fire or as near as safety permits.

NOTE: To determine placement of opening:

- ◆ Soft spot or bubbles
 - ◆ Melting snow or ice
 - ◆ On a wet roof, steam rising or a dry spot
 - ◆ Sense of touch *at the base* of soil or waste pipes
 - ◆ Knowledge of fire location gathered on travel to the roof
 - ◆ Looking over roof edge
 - ◆ Handi-talkie Communication
- B. A rapidly rising column of smoke, with particles or embers ascending to higher levels, visible over the roof top of the building frequently is an indication that the fire is in an open shaft. Due to the shafts area and the heat created therein, the appearance of this heated column is readily distinguished from that rising from a chimney.
- C. Large quantities of black smoke (burning tar) observed over the roof may be an indication of fire at or near the top of the building, namely, top floor fire, cockloft fire, stair bulkhead fire or a fire on the roof.
- D. When encountering membrane roofs the Incident Commander must be notified because the volatility of the roof material may require calling for a line to protect members operating on the roof.

5.5 SEARCH FOR LIFE

A search is an orderly and systematic examination of a building or area for the purpose of locating persons, or locating fire and extension of fire. It consists of a primary and secondary search.

5.5.1 PRIMARY SEARCH

Is a immediate search for life. This primary search is rapid but thorough and systematic.

5.5.2 SECONDARY SEARCH

Is a thorough and painstakingly complete search, to insure that no possible victims are overlooked, as children may hide in closets or under beds or in bathrooms. The secondary search must also include the entire perimeter of the building and all shafts, basements/cellars, etc..

Firefighters must be aware that removal of draperies or curtains and the moving of large objects, or furniture although frequently necessary, may hide a victim or seal off a closet or other area being used as refuge.

Another area that will frequently hide a victim is the entrance door. As a victim will usually try to reach a means of egress, they often can be found in the vicinity of or behind the entrance door.

Officers of units performing search shall be certain that the area in the vicinity of the entrance door, and behind the entrance door are searched for possible victims. After a quick check of this area the room or apartment search can begin.

A thorough search is required on all floors above the fire for several reasons. A partially open door, even on a remote floor, may have allowed an apartment to become heavily charged. This open door would be even a greater hazard on the top floor where heat and smoke could have mushroomed prior to stair bulkhead ventilation. In addition the presence of energy efficient windows may intensify the extension of heat, smoke and gases to the upper floors via pipe recesses and/or improperly fire stopped vertical arteries.

NOTE: IF PRIMARY OR SECONDARY SEARCH IS DELAYED OR NOT COMPLETED FOR ANY REASON, THE INCIDENT COMMANDER MUST BE NOTIFIED.

5.5.3 The public hallway and the entire staircase up to the roof bulkhead door must be examined as soon as possible for those civilians who unsuccessfully attempted to use the interior stairs.

5.5.4 When searching or examining a number of apartments it may be quicker to enter from the related fire escape then to force numerous doors. This does not change normal forcible entry procedure for access to fire floor and the floor immediately above.

5.5.5 If for any reason a thorough search of an area has not been completed the firefighter's officer must be informed and a carefully executed follow-up search shall be initiated. Search for life shall not be confined to the structure alone. The perimeter of the building, shafts, courtyards, etc., must be checked for victims who may have jumped or fallen.

5.5.6 Since the first ladder company is responsible for the fire floor, it shall conduct an exacting primary search on this floor as soon as conditions permit. The second ladder company, which is responsible for the floors above the fire, should conduct a thorough primary search on all floors above the fire. Upon completion of the primary searches, the secondary searches shall be conducted as soon as conditions permit and shall be conducted by units other than those who conducted the primary search of these areas.

5.5.7 FIRE FLOOR

After opening the door, the inside team may find conditions too severe to enter before the Engine Company has their line charged and are prepared to advance. In this instance they should probe the area with a hand or tool, then close the door, being careful that the door does not lock. When the Engine Company has water, immediately crawl in behind the engine company to search and ventilate all rooms.

The Officer of the inside team must be notified before venting is attempted by the OV. After venting, this firefighter shall team up with another available member prior to entry and search. If entry is not possible, this firefighter shall probe the immediate area with hand, foot, or tool. If the adjoining apartment is charged with heat and smoke, the officer of the inside team must be notified by the firefighter that his/her entry will be made into this adjoining apartment for VES when he/she has teamed up with another available member.

5.5.8 FLOOR ABOVE

The second ladder inside team is assigned an extremely difficult position in the apartment over the fire. *Prior to proceeding above the fire the second arriving officer should insure that the officers on the fire floor are made aware of his/her intentions so that those operating above can be warned of any situation necessitating withdrawal.* Initially, they may not always be able to attain this objective, however, they should make an aggressive attempt to gain a foothold on this floor while keeping in mind a safe means of egress. Access to the apartment above the fire may be gained via:

- ◆ Interior stairs
- ◆ Fire escapes
- ◆ Through a common partition wall
- ◆ By crawling across the public hall from a tenable apartment on the same floor if conditions permit
- ◆ Aerial/portable ladder

- 5.5.9 All members operating above the fire must be constantly alert to conditions on the floors below them. The existence of resources to control the fire situation on the fire floor does not guarantee that their position will remain tenable.

When operating on the floors above the fire, members should force one or more doors on each floor to provide an area of refuge if they have to vacate the interior stairs.

IF YOU CANNOT GAIN ENTRY INTO A SAFE AREA AND THE ATTACK LINE IS IN POSITION AND READY TO ADVANCE, YOU MUST IMMEDIATELY RETURN TO THE FIRE FLOOR, BEFORE THE DOOR TO THE FIRE AREA IS OPENED. YOU MUST NOT DELAY THE START OF FIRE EXTINGUISHMENT.

NOTE: The engine and ladder company officers operating on the fire floor must make the units above aware of any conditions affecting their safety. These officers are responsible for the control of the door to the fire apartment.

- 5.5.10 PRIOR TO PROCEEDING TO THE FLOOR ABOVE, ALL OF THE FOLLOWING SHOULD BE CONSIDERED:

1. Life hazard. (known or suspected ?)
2. Status of line.(charged or uncharged ?)
3. Door to fire area.
 - ◆ Forcible entry complete ?
 - ◆ Integrity of door ?
 - ◆ Control of door ?
4. Location and volume of fire.
 - ◆ Fire in front or rear of apartment.
 - ◆ Light medium or heavy fire condition.
5. Has ventilation of fire apartment been effected ?
6. Is roof vented. (skylight, scuttle, bulkhead ?)
7. Type of occupancy. (OLT or NLT ?)
 - ◆ Number of apartments ?
 - ◆ Location of fire escapes ?
 - ◆ Interior stairs (combustible or non combustible ?)
 - ◆ Construction of apartment doors ?
 - ◆ Has building undergone renovations introducing many voids ?

Figure 5-O

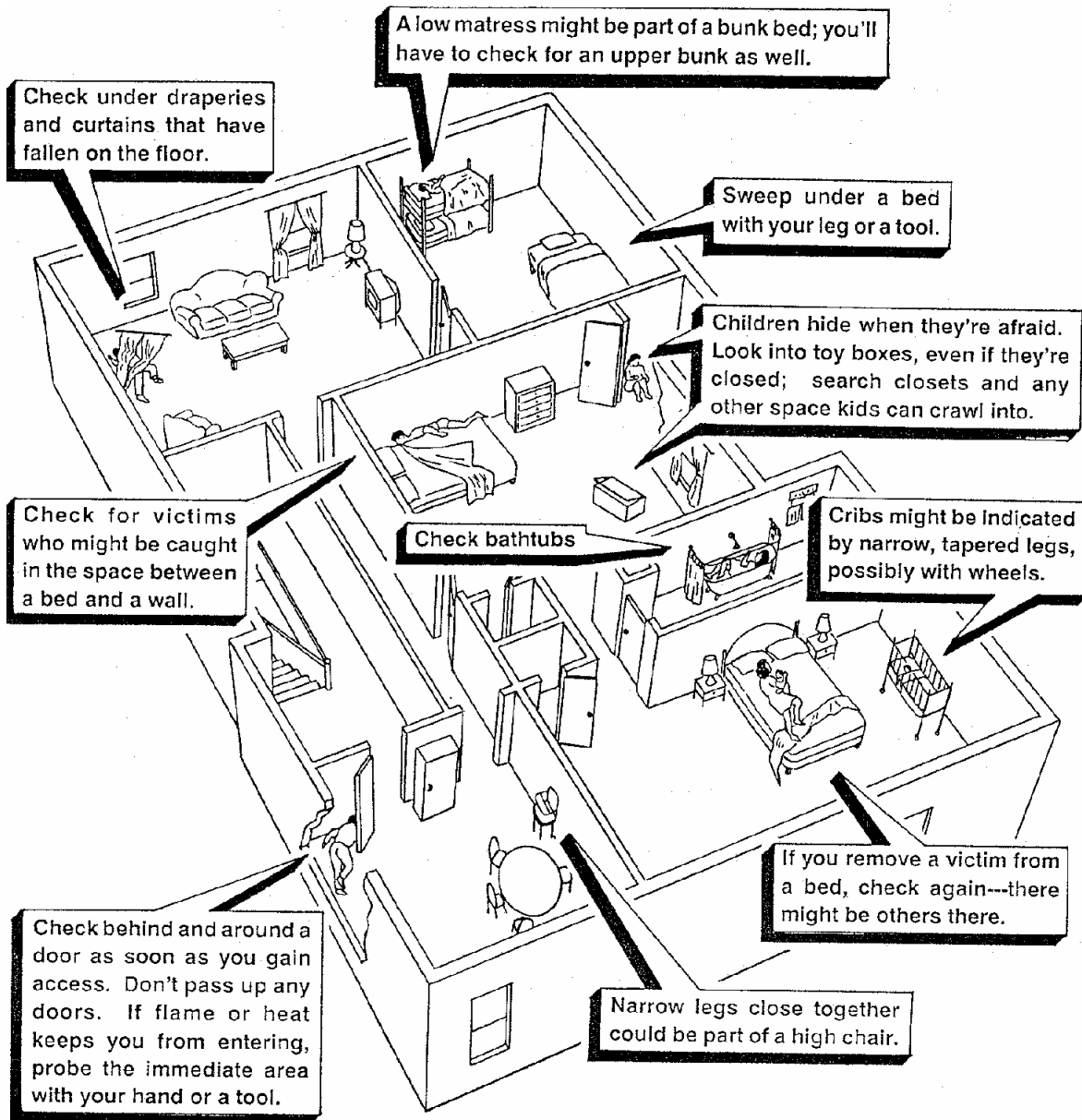
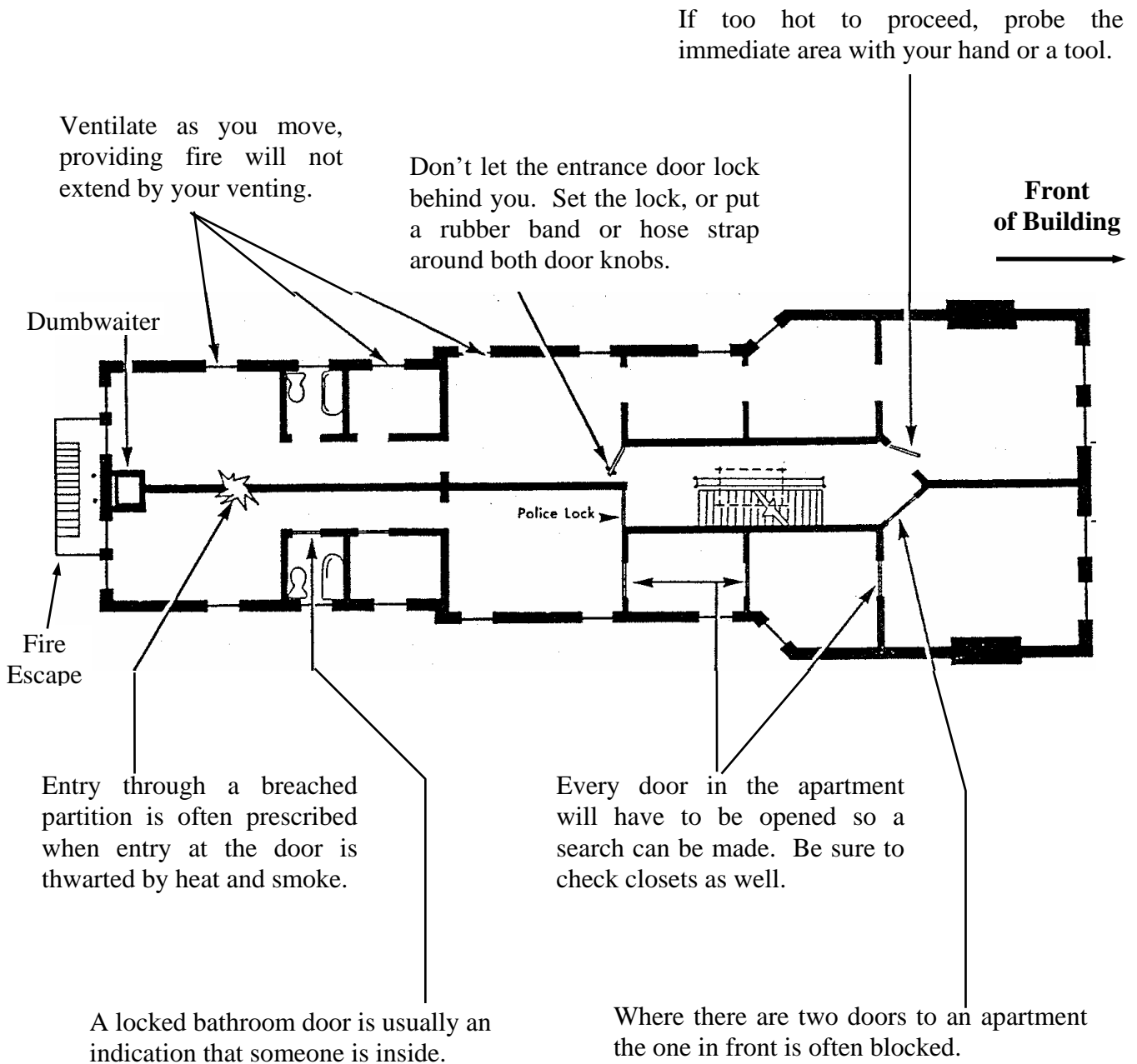

Figure 5P

SEARCHING HINTS
Typical Tenement Floor Plan



5.6 VENTILATION

Ventilation is the systematic removal of heat, smoke and gas from a structure, followed by the replacement with cooler air to facilitate other fire fighting priorities.

5.6.1 Ventilation is a vital factor in all operations and is of particular consequence with respect to the life saving function. Premature or incorrect ventilation may rapidly increase the fires intensity and the area involved causing:

- ◆ Difficulty in extinguishing and confining the fire.
- ◆ Possible death of a victim who could have been removed and saved.
- ◆ Endangering inside team.

5.6.2 VERTICAL VENTILATION

Entails opening the bulkhead door and or roof scuttle or skylight and cutting the roof.

5.6.3 LATERAL VENTILATION (HORIZONTAL)

Entails the opening or removal of the windows of the fire apartment or area.

5.6.4 ENERGY EFFICIENT WINDOWS (EEW'S)

These windows maintain their integrity longer than ordinary single pane windows in a fire environment with the following effects:

- ◆ High heat buildup in fire apartment and floor above.
- ◆ Possibility of a backdraft/flashover.
- ◆ Difficult to vent properly.
- ◆ Cause rapid extension.
- ◆ Discoloration due to high heat is not readily apparent.
- ◆ Difficulty in determining the fire apartment, room or floor.

EEW'S HAVE A MAJOR IMPACT ON VENTILATION PROCEDURE

5.6.5 TIMING/SEQUENCE

Ventilation is a team operation. It is a coordinated action between the inside and outside team through handi-talkie communications.

5.7 VENTILATION OPERATIONAL PROCEDURES

The ladder company officer must control lateral ventilation by the inside and outside team. Uncontrolled lateral ventilation could cause backdraft/flashover jeopardizing the safety of members searching the apartment.

A. *Venting for Life*

Accomplished to facilitate the movement of members into an area where there is a known or suspected life hazard, with an inherent calculated risk of intensifying the fire. It is performed as part of an attempt to reach possible survivors as soon as possible.

Situation No. 1

Inside team enters the apartment first.

The outside team cannot **vent** until given permission by company officer.

Situation No. 2

Inside team unable to enter the fire apartment first.

The outside team must be notified via handi-talkie to attempt VES from exterior. When the attack line is in position and ready to advance, the ladder company officer must communicate with the searching outside team members before the apartment door is opened so as not to endanger their position.

B. *Vent for Fire*

Accomplished to facilitate the engine company advance to and extinguishment of the fire. This venting is normally delayed until the engine company has its water, and is ready to "move in". This ventilation from the exterior is coordinated and ordered by the officer of the inside team.

- 5.7.1 Windows directly exposed to fire across shafts or directly over the fire, should not be opened until the exposing fire is controlled either by partial or complete extinguishment or by having a charged hand line at these extension points. It may be necessary to close windows and remove drapes, curtains, etc.
- 5.7.2 When using a fire escape for access to different floors, never vent a window that could allow fire to cut off the line of retreat.
- 5.7.3 While searching an apartment, severe conditions usually require the firefighters to vent each room as they advance. However, if they do not have another safe means of egress they may necessarily omit venting (or even close) a particular window which might allow fire to cut off their only exit.

5.8 VENTILATION TECHNIQUES

5.8.1 *Venting from the fire escape*

When venting the windows of the fire apartment from the fire escape first check them for heat.

- A. See if they show cracks from the heat.
- B. Look for discoloration of the glass (generally brownish) from the heat.
- C. If still doubtful, remove your glove and feel the glass.

If above observations indicate extreme heat, the fire may momentarily vent itself or light up as you ventilate. To safely vent both windows, first break the window off the fire escape and then the window on the fire escape. (see figure 5R) If the fire escape window is vented first, fire or heat from this window may prevent venting the other window.

NOTE: EEW`s may not give any of these indications, contact inside team before VES.

5.8.2 *Venting from above*

When venting the windows of the fire apartment from directly above by use of a 6` hook (figure 5Q) and an intense fire is suspected, the possibility of fire rolling up the side of the building when air is admitted must be considered. For safety the firefighter should:

- A. Look down at the window to be remove.
- B. Measure the distance with the tool.
- C. Pull head back in the window and then swing the tool through the window below. The firefighter hand and arm will be protected by their clothing.

5.8.3 All members should carry a utility cord for use in operations, e.g., venting of windows on lower floors, guide line during search, raising or lowering tools or hose, etc.. (see figure 5S)

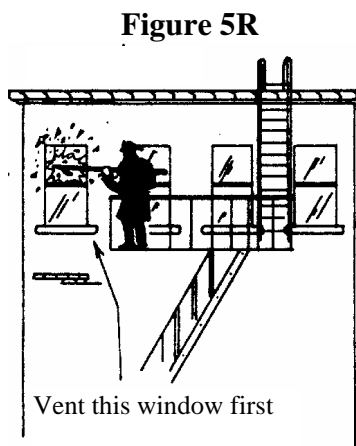
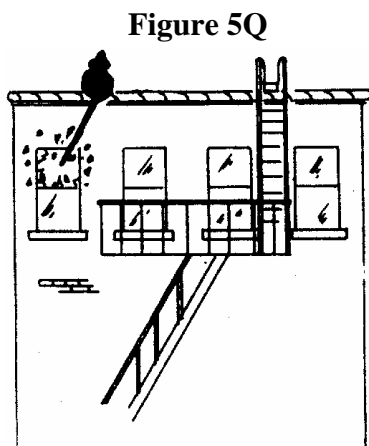

NOTE: Utility cord is not to be used for life saving purposes.

5.9 CUTTING THE ROOF (TOP FLOOR FIRE)

TO BE SUCCESSFUL, THE ROOF OPERATING FORCES MUST FULLY UNDERSTAND THE FOLLOWING:

5.9.1 *WHY*

Prevent horizontal spread and ventilate top floor.

5.9.2 *WHEN*

After preliminary roof ventilation, (bulkhead, skylights, scuttles, windows, etc.) when a serious fire occurs on the top floor or in the cockloft. In all fires it is still of paramount importance to provide rapid initial ventilation before getting involved in the slower work of cutting the roof.

5.9.3 *WHERE*

If possible directly over the fire. To determine this location, check for:

- ◆ soft spots
- ◆ melting snow or ice
- ◆ wet roof, steam or dry spot
- ◆ sense of touch-on the base of soil pipe or vent pipe
- ◆ knowledge of fire location gathered on travel to roof
- ◆ looking over roof edge
- ◆ handi-talkie communication

5.9.4 *HOW MUCH TO CUT*

Initially approximately a 3`x6` coffin cut is recommended:

- ◆ it is more manageable
- ◆ it can be quickly expanded to a larger hole

It avoids the problems associated with holes cut in a roof:

1. *Too large*
Too time consuming, causes delays.
2. *Too small*
Will not grant desired relief and once opened, smoke, fire, and heat might make it too difficult to open further.
3. *Too many holes*
Unsafe. One large expandable hole is more efficient and safer than many smaller holes.

5.9.5 The saw is designed that whenever possible, roof boards and coverings shall be cut in one operation. Sometimes the cut section can be lifted in one piece. When this can not be accomplished, remove the roof covering first, then the roof boards. When many layers of roof covering are encountered, the saw blade may bind.

5.9.6 SEQUENCE

The size and location of the opening will depend on fire conditions. A suggested method to make an expandable opening "COFFIN CUT" is as follows:

- A. Assume wind is blowing in direction indicated. (ideally at your back)
- B. Cut #1 approximately 3 feet.
- C. Cut #2 "knock out" corner cut for tool insertion.
- D. Cut #3 approximately 6 feet.
- E. Cut #4 to #7 approximately 3 feet.
- F. Leave removed pieces of roof section next to opening to warn operating forces.
- G. If larger opening is needed, additional opening can be made in like manner. (continuation of cut in desired direction)
- H. Make sure that roof is not opened before cut is completed.
- I. Push down ceiling to complete ventilation.

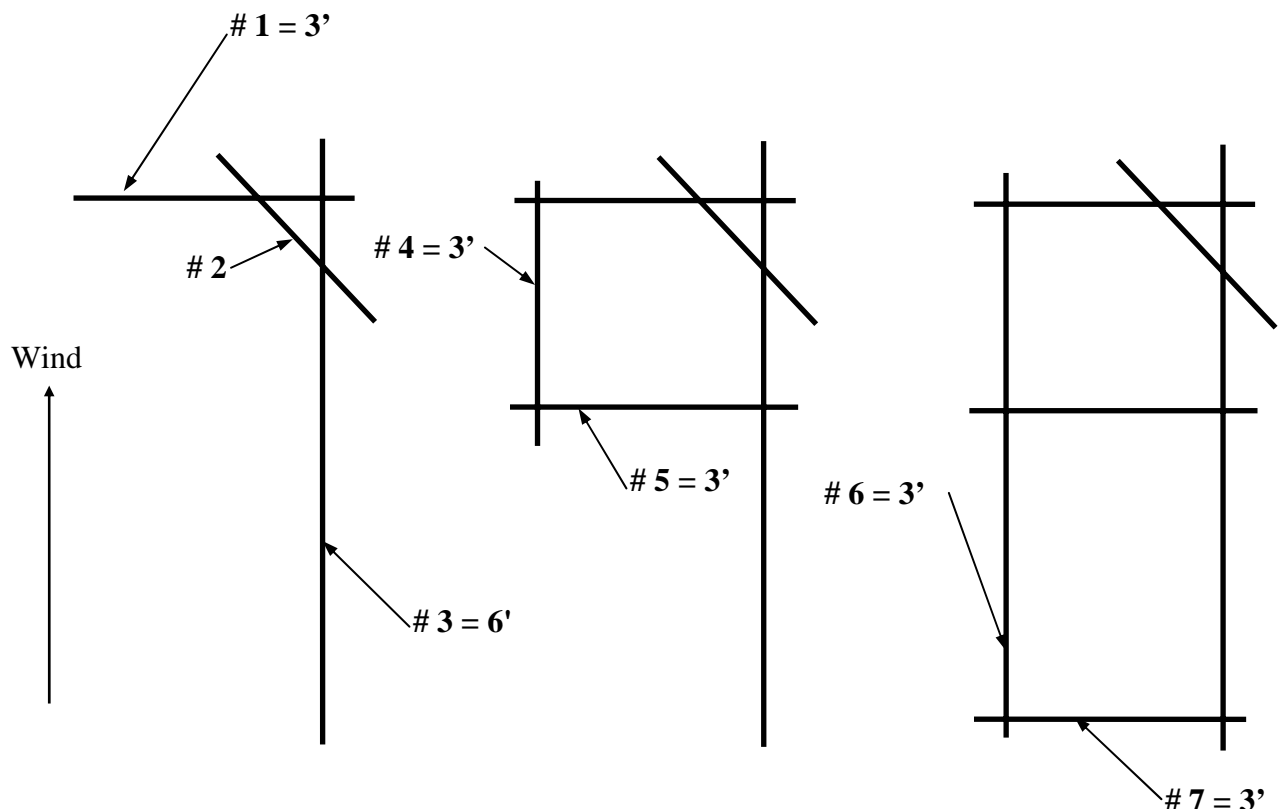

NOTE: When a fire is burning in a top floor apartment, it is not efficient to wait until the fire is "knocked down" before examining the cockloft. An early inspection can be made by going to a room adjacent to the fire (in the same or adjoining apartment) and opening an observation hole in that ceiling. If fire can be seen burning in the cockloft, the observation hole should not be expanded until a charged hoseline has been positioned. It is a good practice while waiting for the charged hoseline to ventilate all windows in the apartment, because once the ceiling is opened the floor will quickly become filled with smoke. This is also the time to make sure that a roof ventilation hole is being cut directly above the fire.

5.9.7 CUTTING THE ROOF WITH AN AXE:

The instructions contained herein are still valid in that total reliance cannot be placed on power equipment and the principles that apply to the use of axes still apply to the use of power saws.

- A. Determine the location of the hole. Cut through the roof covering and remove it, exposing the sheathing. The roof sheathing is placed at right angles to the beams and generally run front to rear. Cut through the sheathing at opposite sides of the proposed opening close to the beam to lessen the bounce of the axe and the resultant binding action when the axe goes through a springy portion of the sheathing. Remove the cut sheathing from the opening with a member on each end of the cut section working in unison to remove tar, tin and nails. Push down the ceiling of the top floor with a 6" hook. (see figure 5T)
- B. The approximate location of the beam may be determined by "sounding" with the back of the axe.
- C. When there is a tin covering between the asphalt covering and the roof boards, it will require an accurate cut to separate the tin from the roof boards. This frequently requires two cutting operations. The first cut is the tar and the tin which is removed prior to cutting the roof boards. It is obvious that this will cause a slight delay in obtaining a roof opening.

Figure 5T

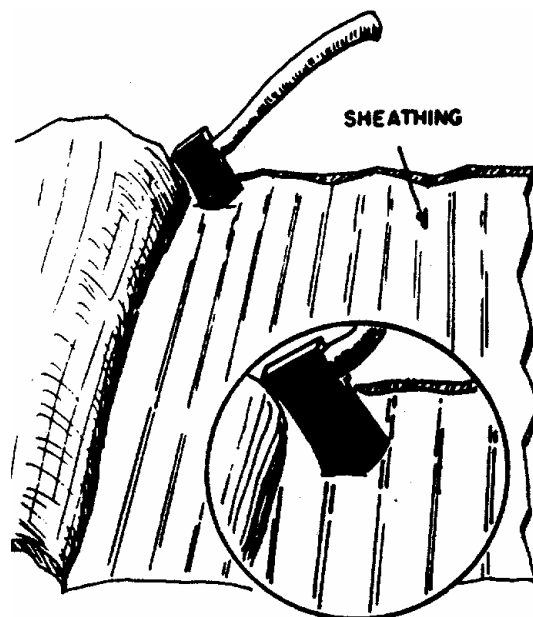

5.9.8 OPERATIONAL NOTES:

- A. When roof stability is in doubt, members must be removed and the incident commander immediately notified.
- B. After cutting the roof the member must also push down the ceiling in order to relieve conditions on the top floor. Using the back of the hook is usually more efficient to push down the ceiling.
- C. Members should always cut with the wind at their back to minimize personal exposure.
- D. A hose line may be necessary on the roof to protect members from roofing surface fires. (membrane)

NOTE: Effective roof ventilation at top floor fires that have extended to the cockloft will be adversely affected or nullified by the operations of streams into or immediately above these roof openings. This not only prevents or retards the vertical movement of heat, smoke and gases but frequently reverses this flow thereby contributing to lateral spread in the cockloft area while intensifying heat and smoke conditions on the top floor which will handicap or halt the interior attack.

5.9.9 SAFETY CONSIDERATIONS:

- A. Try to avoid cutting holes outside bulkhead doors, gooseneck ladders, or other paths of travel.
- B. Member cutting roof must **ALWAYS** be assured of a way of getting off the roof.
- C. Members cutting hole should beware not to endanger other members operating on the roof.

6. ESCAPE

Escape Routes

Proper operation at an intense fire in an Old Law Tenement generally requires that a part of the operating forces be in severely exposed positions if we are to properly perform our search and or rescue mission. The fire condition also requires the ladder chauffeur to remain in front of the building with his/her apparatus anticipating the location of other members and be prepared to position the aerial ladder to provide egress for them when necessary. This, in addition to the member's other previously assigned duties. If early extinguishment is not accomplished, these members will have to withdraw by means of interior stairs, fire escapes or ladders. When these means of escape are cut off an emergency means will have to be considered, such as breaching a wall or partition to an uninvolved area or to a safe means of egress.

6.1 In Old Law Tenements, the infrequently used procedure, of going from front to rear apartments or vice versa through the common partition may also be used as an escape route. To accomplish this:

6.1.1 Use the halligan, hook or axe. This is the order of preference but all can do the job.

6.1.2 Start low. Punch a hole slightly below waist level.

- ◆ This places hole under possible fire stopping between studs
- ◆ Work is less punishing at this level
- ◆ It is easier to push the opposite side of the wall off the studs

6.1.3 The tool is placed in a bay with the bottom anchored against the opposite side of the partition. The firefighter then pulls the tool towards themselves, using short strokes to snap the lath off on their side. Best results are obtained when the opposite side is kept intact until near side is completely removed. (see figure 6A)

Figure 6A

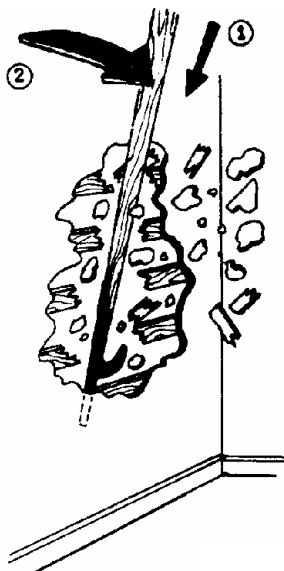

- 6.1.4 With the sole of his/her boot, the member can kick the lath off the far side of the bay.
- 6.1.5 The member then uses the reduced profile for his/her mask and places their head between the studs, turning their body sideways and quickly moving through the opening.

7. OVERHAULING

The term overhauling shall include any opening up of walls, ceilings, partitions, voids, etc. while checking for extension or to extinguish fire during the precontrol as well as during the post control phase of operations. Proper overhauling will expedite final extinguishment and minimize damage to the structure and its contents.

PRECONTROL:

Search for fire and extension which takes place up to the point where the fire is under control. Precontrol overhauling begins as soon as possible after the fire has been knocked down.

POSTCONTROL:

The continued operation that takes place after the fire is under control to insure that there is complete fire extinguishment.

7.1 CHECKING FOR EXTENSION

- 7.1.1 The search for fire extension on the fire floor is started as soon as possible. Many fires do not initially ignite the structure. The contents of a building are ignited and burn first, then the flames spread to the structure. Stuffed chairs, mattresses, clothing or food cooking on the stove are items that initially burn. After the building contents are extinguished, the structure is checked for fire extension. The opening up of ceilings, walls, enclosed pipe recesses, boxed out voids in the fire area and above shall be examined for fire extension.
- 7.1.2 When checking for extension there are six sides to examine in the fire area. The four walls, the ceiling above and the floor.
- 7.1.3 The search for fire extension is often done by sense of touch alone. All places where fire might have extended and display no immediate signs of burning such as discoloration, blistering, smoke, etc. should be examined by touch.
- 7.1.4 At a top floor fire that has extended into the cockloft, the roof firefighter will have cut a hole in the roof and pushed down a portion of the ceiling. Enlarge the opening in the ceiling so that the engine company may operate into the cockloft from a high vantage point (table, bureau, chair, etc.). Sweeping the cockloft with the stream if necessary. Continue pulling the ceiling until certain the fire is extinguished and involved areas are exposed.

- 7.1.5 Properly installed fire stopping is recognized as a great aid in the prevention of both lateral and vertical fire extension. Unfortunately, poor workmanship, deterioration due to age, subsequent repairs and renovations, failure to provide any fire stopping initially, electrical and plumbing installations, etc. do not allow complete reliance to be placed on this structural feature in Old Law and New Law Tenements.
- 7.1.6 The partitions that separate apartments in Old Law Tenements are not fire stopped between the ceiling of one floor and the under side of the floor above. This may permit lateral extension across the building and could be first discovered by the unit working on the floor above the fire floor when they encounter extension and/or an unusually heavy smoke condition in the apartment which is not directly over the fire apartment.
- 7.1.7 In Old Law Tenements, the floor beams are laid parallel to the front of the building thus forming horizontal channels for fire travel as far as both side walls (bearing walls) of the building. This construction not only permits lateral fire spread within the building but allows possible extension into adjoining buildings via beam ends and/or defective masonry. An exception exists where these horizontal arteries are interrupted by public hall and stairs which retard lateral extension. Where these horizontal channels terminate at air shafts, they have allowed fire which has burned through flooring to the apartments above to extend via shaft windows to either or both adjoining buildings.

Figure 7A

New Law or renovated Old Law Tenement

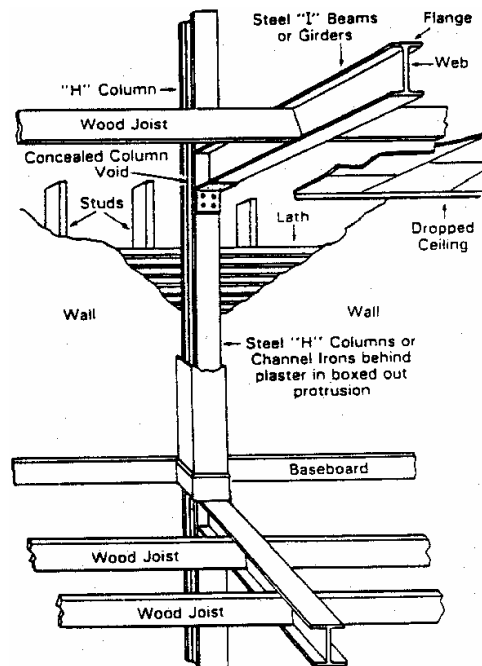

Beams encased from floor to void in dropped ceiling create an excellent flue for fire to extend both vertically and horizontally, rapidly involving all floors.

Figure 7B

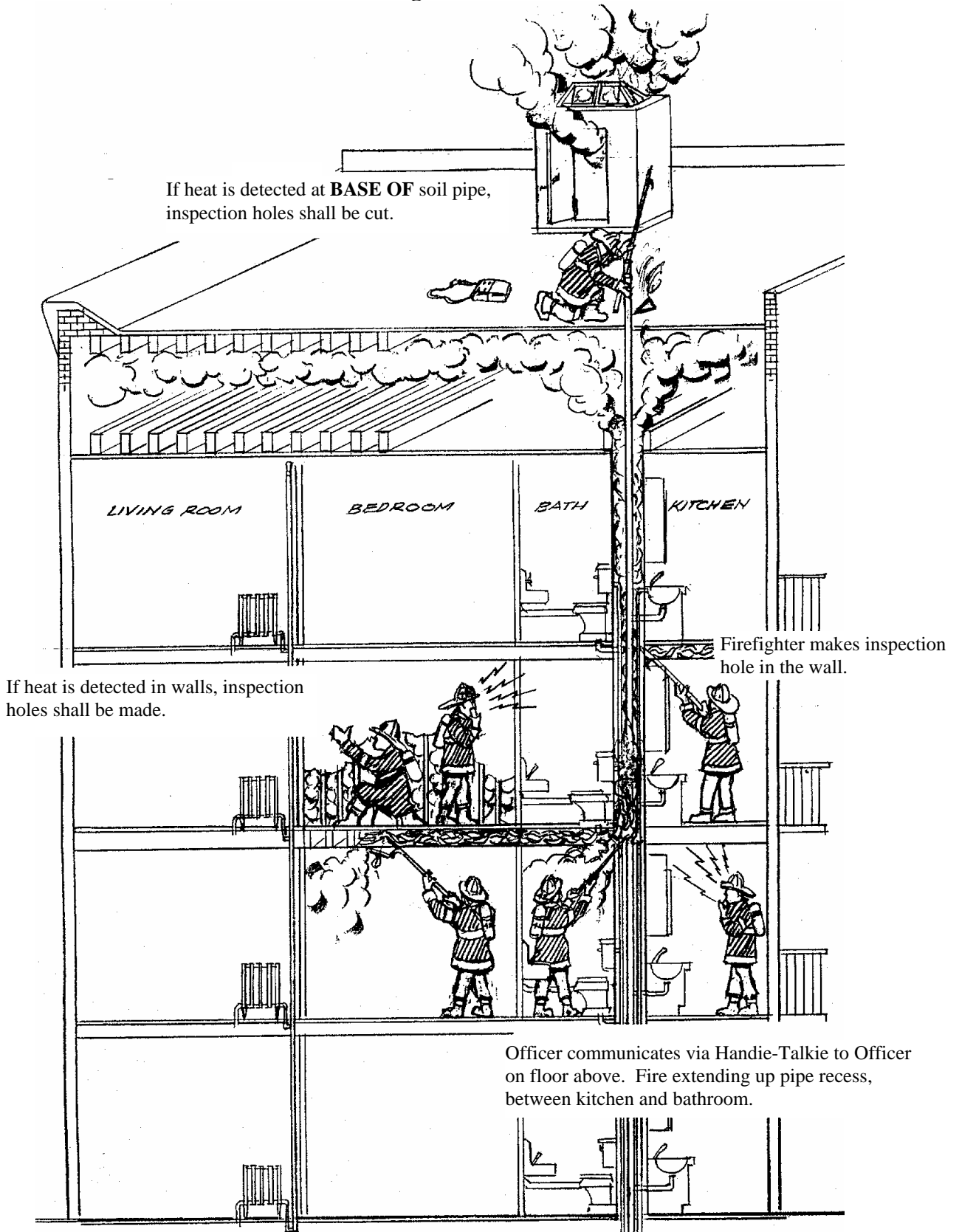

7.2 1ST ARRIVING LADDER COMPANY (FIRE FLOOR)

- 7.2.1 After the fire has been knocked down it is the responsibility of the first ladder company to arrive to determine if the fire is extending and where it is extending. This information should be transmitted to the Incident Commander and the ladder company on the floor above. (see figure 7B)
- 7.2.2 The ceiling should be opened first by starting at a point where the fire was most intense and working towards a clean area of ceiling space. The ceiling light fixture area should be pulled and examined.
- 7.2.3 Any horizontal or vertical voids, whether pipe recesses, electrical conduits, channel rails, etc. are found once the ceilings and walls are opened must be examined. If fire has extended, this information should be transmitted to the Incident Commander and to the ladder company on the floor above. (see figure 7B)
- 7.2.4 Fire that is found in ceiling bays or adjacent to steel beams that cross over partitions separating other uninvolved rooms or apartments must be inspected by pulling ceilings.
- 7.2.5 *Boxed out protrusions:* These boxed out voids can contain pipe risers, electric conduit, chimney flues, steel columns or sealed dumbwaiter shafts which run from the ceiling to the cockloft.
- 7.2.6 *Steel Columns:* Steel columns and beams can be found in N.L.T. or O.L.T.. Boxed out areas around a steel column create a natural void. If a boxed out protrusion on a wall contains a steel column and was involved in fire, then the entire length of this void will have to be examined. Particularly its highest point, the cockloft, will have to be inspected. (see figure 7A) Also, burning embers can easily drop down this void and start a fire on the lower floors.
- 7.2.7 *Closets:* Their construction on top of one another provide a vertical artery. Workmanship can be shoddy, creating openings for fire travel. They should be checked for voids.
- 7.2.8 *Walls:* Wall switches, receptacles and fuse boxes (circuit breakers) are locations for fire to enter and travel. Especially when burning furniture is against the wall.
- 7.2.9 *Floors:* The flooring in the fire area must be checked. If the flooring is charred, the ceiling below should be examined for fire extension.

NOTE: There may be no subflooring in O.L.T.'s. This may allow fire to extend rapidly up and down.

7.3 2ND ARRIVING LADDER COMPANY (FLOORS ABOVE)

- 7.3.1 A smoke condition at the apartment entrance is not enough reason to believe that fire has extended to this floor. However, high temperatures even only at the ceiling level or a crackling sound heard within the apartment or a fiery glow seen through the smoke are all indications of fire extension and justify calling for a hand line.
- 7.3.2 There is no exact way that temperature can be determined by touch, but if a wall or a partition is too hot to keep the hand on, it should be opened up. The 6` hook is used to open at any point where the fire may have entered (pipe recesses, electrical fixtures, etc.). The opening should be made above the hot spot to cut off extension. As the studs are generally 16" to 24" apart, it is important to feel for heat at proper intervals so that no bays are skipped. If fire is found in a bay, it and both adjoining bays should be opened for examination.
- 7.3.3 On a floor above a heavily involved apartment, considerable smoke and heat will be in evidence around the baseboards. If extension at this point seems possible, the baseboard is loosened and if necessary pots of water may be poured between baseboard and wall to control this extension pending engine company operations. Any of the basic tools can be used to open the baseboards. The most efficient and safest way is to start at a corner or joint and work along prying the baseboard out from the wall. Every effort should be made to keep it in one piece so that it may be replaced.
- 7.3.4 Pipe recesses on the floor above must be examined for extension and if necessary controlled as mentioned in 7.3.2., in order to determine the area where the fire might have extended vertically. The officer assigned to the task of overhauling the floors above the fire should make an examination of the room or floor where the fire originated. This knowledge will allow him to be more accurate in the search for hidden fire when working on the floor above.
- 7.3.5 If fire is found extending to the floor above, probing holes are made in the same bay or bays until the outer edge of the fire is defined. **THE CEILING OR WALLS SHOULD NOT BE FULLY OPENED UNTIL A CHARGED LINE IS IN POSITION, BECAUSE OF THE POSSIBILITY OF INTENSIFYING THE FIRE.**
- 7.3.6 If extension of fire is found passing the floor above via vertical avenues (pipe recesses, etc.) the Incident Commander must be notified.

7.4 OPENING UP CONCEALED SPACES

7.4.1 THE 6' HOOK.

A. *Pulling ceilings* (figure 7C)

Beams in Old Law Tenements generally run parallel to front and rear walls. Lath is attached at right angles to the beams and runs front to rear. Each piece of lath usually covers two or more bays. The ceiling is penetrated with one firm stroke with the hook end parallel to the lath. This breaks only one lath on the upstroke instead of two or three. The hook is then turned to form a right angle to the lath and the ceiling is pulled with short, sharp strokes close to the beam. This method is fast and conserves energy. The firefighter should not stand directly below the ceiling being pulled. They should keep the work in front of them. In close quarters firefighters shall keep their heads down to prevent injury. Eye shields shall be used.

NOTE: WHEN PULLING SHEET ROCK CEILINGS, BE AWARE THEY MAY FALL IN LARGE HEAVY SECTIONS.

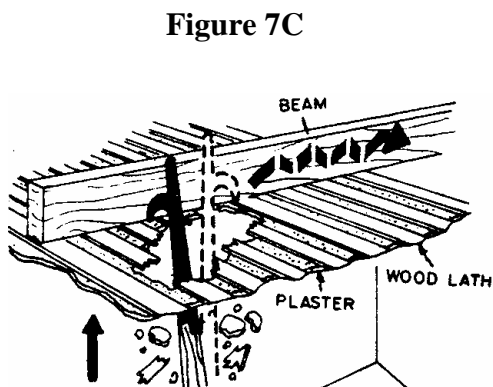
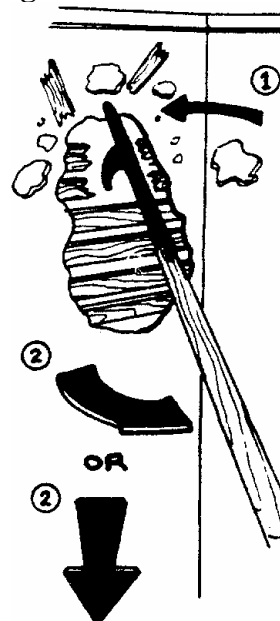

Figure 7D



B. To make a hole high in a sidewall or partition of lath and plaster. (figure 7D)

This requires a sharp blow with the hook. After penetration with the hook, the tool is used to pull down or pry out if leverage is possible.

Figure 7E

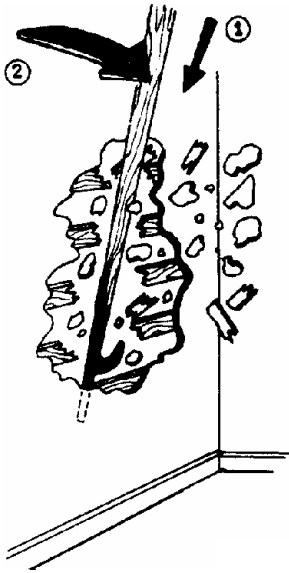

Figure 7F



- C. To make a hole low in a side wall or partition. (figure 7E)
The hook is held like a javelin before penetrating the wall. After an opening has been made, the hook is then pushed down behind the lath and the lath is removed by pulling the handle. This should open the wall to the floor or baseboard. When prying with the hook, excessive strain which may break the wooden handle must be avoided.
- D. Use the handle of the hook, or the point to make small probing holes to check for extension or to allow water to flow out as opposed to pulling. (figure 7F)

7.4.2 CUTTING A FLOOR (figure 7G)

Flooring is seldom cut at tenement fires as it is easier and faster to pull the ceiling below for examination. If a hole must be made, the cuts that are parallel to the joist should be made close to the opposite joists of the bays adjoining the one we wish to expose. This will insure that the entire bay and joists are exposed as well as the two adjoining bays.

If the floor is cut in this manner it will also eliminate any unsupported section of flooring.

Primary Method:

- A. *Cutting with saw*
because it is the most efficient. Area must be vented to prevent buildup of carbon monoxide.
- B. *Cutting with axe*
Cut floor at a 60 degree angle and on a bias as shown. This is easier than cutting across the grain.

Figure 7G

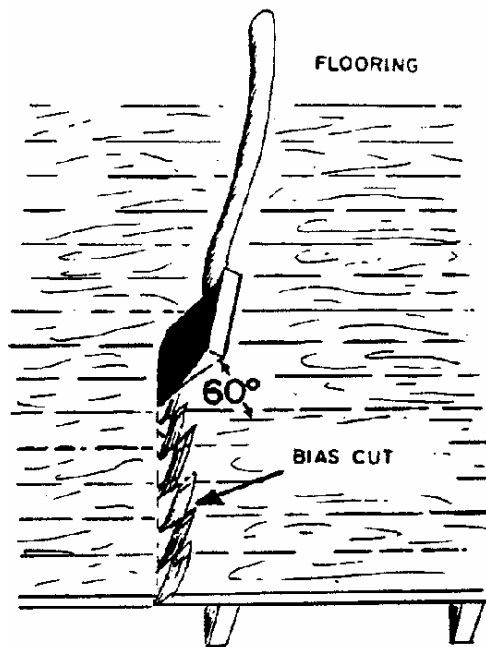

7.4.3 TRIMMING A WINDOW OR DOOR

The complete removal of a window frame is seldom required. They are generally set into the brickwork and extension from them cannot occur except to a space between the plaster and the side wall of the building. Similarly, extension around a door frame is usually limited to the space between the door frame and the studs forming the rough opening.

The trim around windows and doors is put on last during the construction stage and should be the first pieces removed if examination is required at these points. Removal of the trim is generally sufficient to allow an adequate examination and application of water.

Depending on the tool being used, the most efficient and safest way to remove the trim is to start at the top or bottom corner or joint and work along prying the molding out from the wall.

8. SAFETY

This section will cover safety suggestions generally applicable during the postcontrol phase of overhauling operations. Safety considerations during the precontrol phase of overhauling are incorporated in appropriate parts of the "Operational Plans" (Sections 2&3) and "Operational Techniques" (Section 5).

- 8.1 Dispatch a member if other tools are needed. The right tool for the job will save time and energy.
- 8.2 It is dangerous for more than one or two members to use tools at the same time in a small area, such as rooms in Old Law Tenements.
- 8.3 Members must be relieved frequently to conserve their energy and prevent accidents.
- 8.4 In warm or hot weather, the Incident Commander may permit the members to remove their bunker coats to reduce the debilitating effects of excessive perspiration. However, they must always wear bunker pants, boots, helmets and gloves while overhauling.
- 8.5 Adequate lighting is required at all times.
- 8.6 Holes in the floor are generally small and must be protected, generally by placing a door over them. Holes in the roof will be much larger and all members must be warned to be constantly alert. A roof door or short ladder may be used to cover danger spots.
- 8.7 Bulging or hanging plaster should be removed from walls or ceilings.
- 8.8 Hanging wood lath, metal lath, or tin from a ceiling should be trimmed off and removed.
- 8.9 Tin should be folded to a size making it safe to carry and placed outside away from the line of travel. A minimum amount of handling of tin is advisable to reduce the injury hazard.

- 8.10 Hanging ends of cable such as electric (BX), telephone and coaxial television shall be secured near the ceiling. Loops of cable hanging down shall be pushed up out of the way. Consider the removal of electric power when appropriate.
- 8.11 Where it is obvious there will be considerable overhauling, Incident Commanders should consider retention of a work force adequate to complete the job in a reasonable period of time.
- 8.12 Smoldering goods such as clothing, upholstery, carpet, etc. can produce an abundance of carbon monoxide and other toxic gases. For this reason such material should be completely extinguished and or removed from the premise.
- 8.13 Officers must not permit any material to be thrown out of windows unnecessarily. A member should always be posted in the yard or street below to prevent injuries to anyone from falling material. Examination of the yard must be made before discarding any material into the yard to assure that no occupants have jumped into the yard prior to the arrival of Fire Department units. No material shall be thrown onto roof of buildings or into narrow shafts or setbacks.
- 8.14 Before exiting building you must "STOP" until you are assured it is safe to exit the building.
- 8.15 Whenever a member operates on a ladder of any kind, they must have enough hand control to ensure their safety. This is an absolute necessity when on vertical ladders, such as fire escape drop ladders and goose neck ladders to the roof. Greater physical effort is needed when using a completely vertical ladder, because a missed step or a slip of a hand will result in a vertical drop and a serious injury. A similar mishap on a ladder which is angled into an objective could result in a member falling toward the ladder rather than straight down.
- 8.16 Care should be exercised when overhauling in bathrooms. A sudden collapse of the flooring due to fire weakening, rotting of the floor beams, the weight of the fixtures (cast iron tubs) and tile floors can occur. Consider using the reach of the hook and standing outside the bathroom to open up the ceiling.
- 8.17 At greater alarms, Incident Commanders should give consideration to the relief of entire units that might be physically spent from their efforts to contain and extinguish the fire.
- 8.18 When using saws and generators while overhauling within a building adequate ventilation must be provided.
- 8.19 When on fire prevention activities or other outside activities that require a roof inspection, members can learn to differentiate between a normal and a weakened roof. Any conditions or hazards that could jeopardize operations or safety should be submitted on CIDS cards. (e.g., membrane roofs)

9. OPERATIONAL NOTES

- 9.1 All members should have a working knowledge of construction features so that they will be aware of the avenues of fire travel, exposures and the simplest manner of opening up for examination, i.e. the trim around windows and doors is put on last during the construction stage and should be the first pieces removed if examination is required at these points.
- 9.2 Trim, baseboards, etc. shall be removed in a professional manner so that those structural members not deeply charred may be preserved for future use.
- 9.3 The removal of major structural elements is a very serious matter. Floor joists or roof joists should not be removed if complete extinguishment can be accomplished in any other manner. *LINTELS* in brick walls over exterior doorways and *windows should not be removed*, regardless of charring, as they support a considerable amount of brickwork. To remove them from their anchorage could result in injury and considerable property damage through partial collapse.
- 9.4 Usually the ceilings and walls are constructed of lath and plaster and will have been opened and examined for fire extension in the precontrol phase. These openings may prove adequate for examination purposes. In some instances charring may extend into sections that have not been pulled. This lath and plaster must be pulled until the bay shows clear and there is no evidence that fire has extended beyond this point.
- 9.5 When ordered to pull lath and plaster in the post control phase:
- A. The floor is examined first to make sure that burned material or flooring requiring examination is not covered.
 - B. The beds are taken apart and removed or placed out of the way.
 - C. Articles from the tops of dressers, bureaus, tables, etc. should be removed to a place of safety such as a drawer.
 - D. Furniture that is in the way should be covered or removed to prevent further damage.
- 9.6 Small fires may be cut out with a knife and submerged in water in a suitable receptacle. Where the stuffing is involved with smoldering fire, these articles should be removed to the street to prevent rekindle. If a supply of fresh air comes in contact with incompletely extinguished foam rubber, there is a danger of the foam rubber bursting into flame and producing vigorous flaming combustion over its entire surface area. This situation could cause serious injury to any one in close proximity to the foam rubber. Prior to removing these items to the street, they must be completely examined to ensure complete extinguishment.
- 9.7 *Wooden Furniture*
It is rarely necessary to remove these articles. Tables and hardwood chairs can be placed in a safe location and protected from further damage. Dressers and bureaus must be searched for smoldering fires in, behind or around the drawers. The smoldering articles should be immersed in water and salvageable items returned to the drawers with the entire object remaining in the apartment.

- 9.8 Wooden structural members that are deeply charred may be removed from the building. Those that have merely been scorched or on which the paint has been blistered shall be left in the apartment for possible reuse.
- 9.9 The removal of involved materials to enclosed shafts or roofs of setbacks is not to be permitted.
- 9.10 When material must be removed from the fire building, the area where this material will be deposited must, itself, be checked before proceeding. This eliminates the possibility of covering hose lines, tools, cellar doors, drains or victims who may have jumped prior to our arrival.
- 9.11 To reduce water damage:
- ◆ Scorched hangings, bedding or clothing shall be used to absorb excess water on floors.
 - ◆ Excess water may be channeled into wastelines, dumbwaiter shafts, etc.. Every effort should be made to prevent water flowing down through the building. There are no water proof areas in Old Law Tenements.
 - ◆ Buckets, basins or other receptacles may be used for dipping scorched material, but avoid stopping the drains of sinks and tubs.
- 9.12 When water has seeped down through several floors, the possibility of wet wires and short circuits require that fuses be removed or circuit breakers opened for the affected areas and apartments.
- 9.13 If meter, stove or gas supply lines are damaged , gas must be shut off.
- 9.14 Electric or gas supplies shall not be returned to use once shut off. Restoration shall be by authorized crews of the affected utility companies.
- 9.15 Before the department leaves a premises:
- ◆ All broken glass must be trimmed from window frames so that glass shards will not fall causing injury or damage.
 - ◆ Replace or position all drop ladders.
 - ◆ Check for all assigned tools and equipment.

10. SUPERVISORY OBJECTIVES

Overhauling has been dealt with broadly but the following objectives should be kept constantly in mind. Make a critical analysis of your attitude and evaluate your overhauling practices in light of these objectives.

- 10.1 Time and energy will be saved by systematically planned overhauling and the proper use of manpower, tools and equipment. This facilitates the return of companies to "in service" status and eases the work load for those companies who remain at the scene.
- 10.2 Protection of property regardless of ownership is a primary consideration. Officers must approach overhauling as though the overhauling were being performed in their own homes and they were in the unfortunate position of being uninsured for the loss.

- 10.3 All Officers shall make every attempt to prevent a rekindle. This requires knowledge, skill and practical application. Never hesitate to open and expose hidden areas when reason dictates that it is required. Select the least destructive method of making this examination whenever possible. Never open indiscriminately without knowing why the opening is necessary.
- 10.4 Minimize exposure of personnel both in time and danger. The major portion of fire duty is spent in overhauling and a considerable number of loss of time medical leaves are incurred during this period. The proper use of tools, recognition of the hazards, good practices and close supervision are all required to reduce the injury and illness rate.
- 10.5 Professionalization is the aim of the entire department. It includes all of the good practices already mentioned as well as public relations. You should be able to justify your actions by simple explanations to the uninitiated where the extent of damage may not be completely understood. Sound practices have sound reasons.
- 10.6 Conditions at the scene of a fire often indicate whether or not the overhauling was handled in an orderly, systematic manner. Broken glass hanging from window frames, debris covered hose lines, unburned furniture and clothing lying on the street and/or personal garments left hanging from fire escapes or window sills are definite indications that competent practices were not adhered to. This does not mean that burned clothing, structural members, furniture, etc. with a potential for reignition cannot be removed to the street. Discrimination and professional judgment must be used.

11. CONCLUSION

The key to successful operations is training.

Preplanning, group discussions, drills and *post fire critiques* all aid immeasurably in the development of an efficient fire fighting unit. They, in turn, provide the climate for the teamwork and coordination that is so vital at tenement fires where lives so frequently depend on the proper execution of numerous and diverse assignments. Assignments should be carried out and objectives achieved. Timing and exacting team work are essential to an efficient operation. A singleness of purpose is necessary to avoid distraction, duplication of efforts and a resultant delay in the attainment of individual objectives. If firefighters have to improvise to accomplish their objectives, then that too becomes part of their tasks. Decisions on the fire ground must be made instantaneously and under great stress. The professional firefighter continuously studies their responsibilities so that they are fully prepared to make the best decision possible when confronted with difficult or unusual situations.

BY ORDER OF THE FIRE COMMISSIONER AND THE CHIEF OF DEPARTMENT